

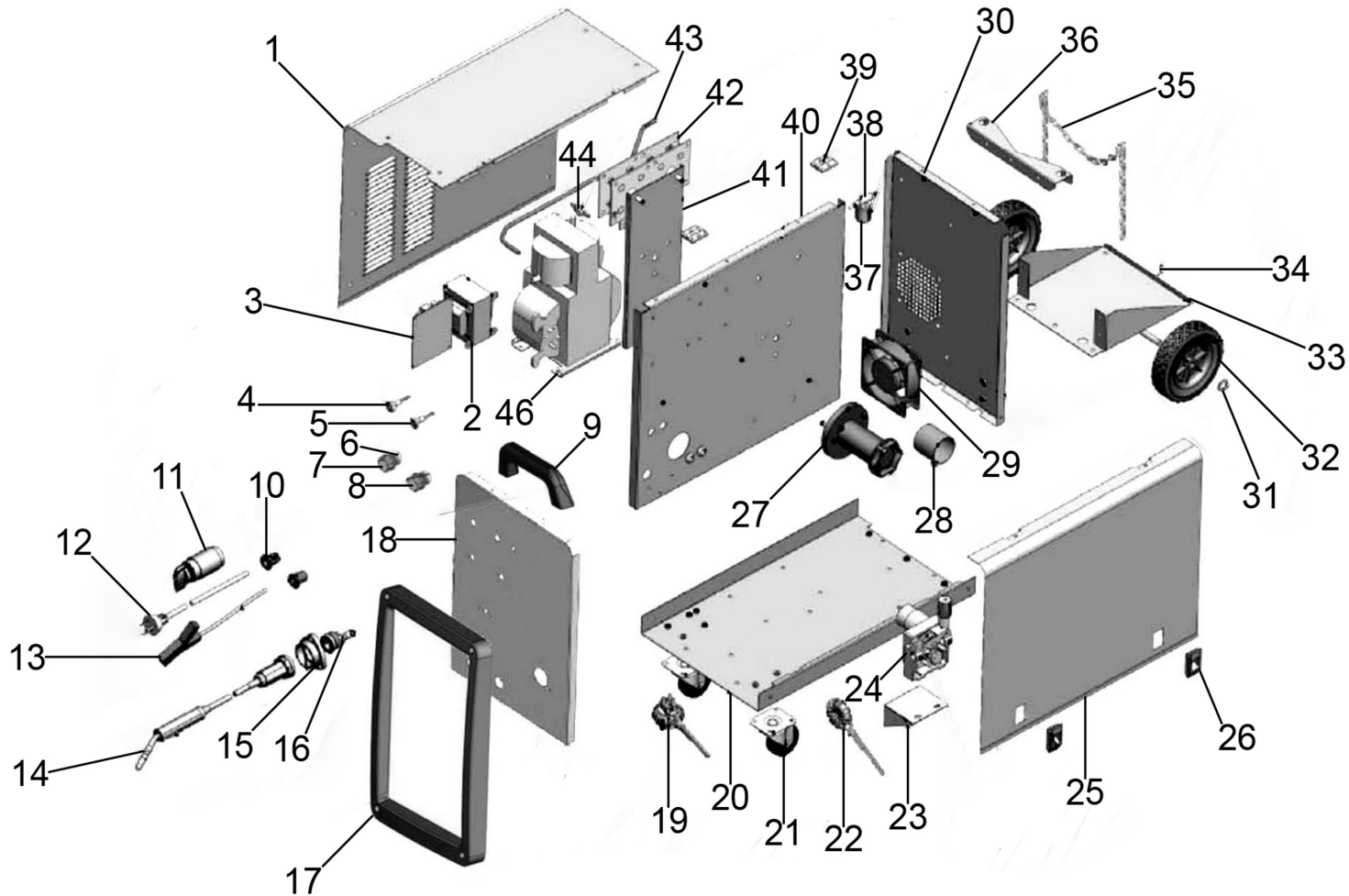

Parts Information:
Professional MIG Welder 180A 230V with Binzel® Euro Torch
Model No: SUPERMIG180.V3



NOTE: It is our policy to continually improve products and as such we reserve the right to alter data, specifications and component parts without prior notice.

There may be alternative versions of this product, please contact us should you require this information.

IMPORTANT: No liability is accepted for incorrect use of product. Spare parts must be fitted by a competent person

WARRANTY: Guarantee is 12 months from purchase date, proof of which will be required for any claim.

Sealey Group, Kempson Way, Suffolk Business Park, Bury St Edmunds, Suffolk. IP32 7AR



01284 757500



01284 703534



sales@sealey.co.uk



www.sealey.co.uk



Parts Information:
**Professional MIG Welder 180A 230V with
Binzel® Euro Torch
Model No: SUPERMIG180.V3**

Item	Part No.	Description
1	SMIG180.V3-01	Side Panel, Left
2	SMIG230.02	Control Transformer
3	SMIG180.V3-03	PCB
4	SMIG230.04	Indicator, Green
5	SMIG230.05	Indicator, Yellow
6	SMIG180.V3-06	Potentiometer
7	PMIG6035S.W25	Knob, Potentiometer
8	SMIG180.V3-08	Potentiometer (c/w Switch)
9	SMIG230.09	Handle
10	250XTD.28	Cable Holder
11	SMIG180.V3-11	Switch, Rotary (c/w Knob)
12	MC3CX2.5	Mains Cable
13	SMIG180.V3-13	Earth Cable
14	MIG/T15	Torch, 3m Euro Connector MB15
15	SMIG275.24	Torch Holder
16	SMIG230.16	Euro Connector
17	SMIG230.17	Frame
18	SMIG180.V3-18	Front Panel
19	SMIG180.V3-19	EMC
20	SMIG230.20	Bottom Panel
21	SMIG230.21	Wheel, Swivel Castor
22	SMIG180.V3-22	Wire Drive Assembly
23	SMIG180.V3-23	Plate, Wire Feed
24	SMIG230.24	Wire Feed Motor 24V

Item	Part No.	Description
25	SMIG180.V3-25	Side panel, Right
26	SMIG275.14	Door Lock
27	SMIG275.45	Spool Holder
28	SMIG180.V3-28	Spacer, Spool
29	180XT.19	Fan
30	SMIG230.30	Back Panel
31	FWM12.S	Flat Washer M12
32	SMIG230.32	Wheel
33	SMIG230.33	Bracket, Gas Cylinder
34	800TTJ.41	Cotter Pin
35	SMIG180.V3-35	Chain
36	SMIG230.36	Support, Gas Cylinder
37	SMIG180.V3-37	Gas Connector
38	SMIG180.V3-38	Gas Valve
39	SMIG275.12	Hinge
40	SMIG230.40	Middle Panel
41	SMIG230.41	Panel, Spool Holder
42	SMIG230.42	Rectifier
43	SMIG180.V3-43	Gas Hose
44	SMIG180.V3-44	Thermal Relay
46	SMIG180.V3-46	Transformer (c/w Reactance)
--	120.990704	Gas Hose (c/w Clip)(Not Shown)
--	SFS612.S	Hex Head Flange Bolt M6 x 12mm (Not Shown)
--	MIG/GH	Gas Hose, Black Nylon Ø5mm (Not Shown)

NOTE: It is our policy to continually improve products and as such we reserve the right to alter data, specifications and component parts without prior notice. There may be alternative versions of this product, please contact us should you require this information.

IMPORTANT: No liability is accepted for incorrect use of product. Spare parts must be fitted by a competent person

WARRANTY: Guarantee is 12 months from purchase date, proof of which will be required for any claim.

Sealey Group, Kempson Way, Suffolk Business Park, Bury St Edmunds, Suffolk. IP32 7AR



01284 757500



01284 703534



sales@sealey.co.uk



www.sealey.co.uk