

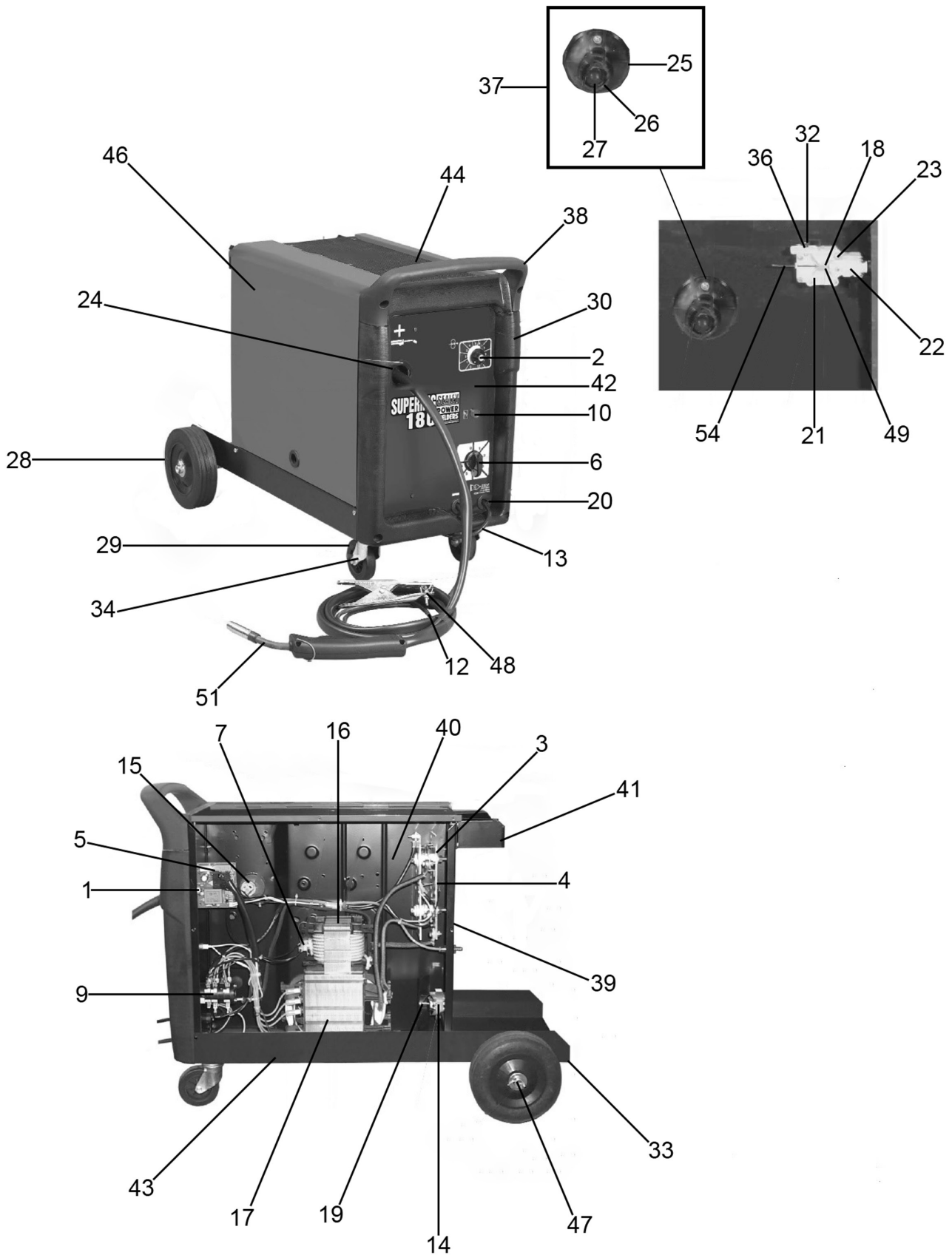

Parts Information:
Professional MIG Welder 180Amp 230V
Model No: SUPERMIG180.V2



NOTE: It is our policy to continually improve products and as such we reserve the right to alter data, specifications and component parts without prior notice. There may be alternative versions of this product, please contact us should you require this information.

IMPORTANT: No liability is accepted for incorrect use of product. Spare parts must be fitted by a competent person

WARRANTY: Guarantee is 12 months from purchase date, proof of which will be required for any claim.

Sealey Group, Kempson Way, Suffolk Business Park, Bury St Edmunds, Suffolk. IP32 7AR



01284 757500



01284 703534



sales@sealey.co.uk



www.sealey.co.uk



Parts Information:
Professional MIG Welder 180Amp 230V
Model No: SUPERMIG180.V2

Item	Part No.	Description
1	120.113533	Potentiometer
2	120.121424	Knob, Potentiometer
3	120/112183	Protection, Rectifier
4	120.980476	Rectifier Kit
5	120.980465	PCB, Wire Feeder Board
6	120.323101	Knob, Switch
7	120/122525	Thermostat
9	120.121510	Switch, Rotary 16A 500V 50Hz
10	120/122529	Lamp, Yellow
12	CC16/1	Copper Cable Ø16mm
13	MC3CX2.5	Mains Cable
14	120/152080	Motor, Electrofan
15	120.981848	Motor, Wire Feed
16	120.169371	Reactance
17	120.169296	Transformer
18	B/609Z	Bearing
19	120/312025	Blade, Fan
20	120.322112	Bushing
21	120/322126	Casing, Feeder Roller Shaft
22	120/322127	Casing, Torch Fixing
23	120/322128	Bracket, Counter Roller
24	120/322143	Ring Nut, Cable Protection
25	120/322172	Spindle
26	120/322173	Ring Nut, Reel
27	120/322174	Thumb Screw, Reel

Item	Part No.	Description
28	120/322201	Wheel, Fixed
29	120/322245	Wheel, Fixed
30	120.322640	Plastic Frame
32	120/422257	Tension Knob, Counter Roller
33	120/422817	Bracket, Axle
34	120/422820	Bracket, Castor
36	120/452022	Spring
37	120/990288	Reel Kit
38	120/312328	Handle
39	120/644828	Back Panel
40	120/644176	Diaphragm
41	120/644606	Bracket
42	120.649562	Front Panel
43	120.644961	Bottom Panel
44	120.655310	Cover
46	120.655309	Door
47	120/681092	Axle, Wheel
48	120/712231	Work Clamp
49	120/722019	Feed Roller
51	120/742405	Mig Torch
54	120/990097	Guide Hose
--	120/432102	Bull Nose Adaptor (Not Shown)
--	REG/MT	MIG Gas Regulator (Not Shown)
--	120/990251	Gear Set (Not Shown)

NOTE: It is our policy to continually improve products and as such we reserve the right to alter data, specifications and component parts without prior notice. There may be alternative versions of this product, please contact us should you require this information.

IMPORTANT: No liability is accepted for incorrect use of product. Spare parts must be fitted by a competent person

WARRANTY: Guarantee is 12 months from purchase date, proof of which will be required for any claim.

Sealey Group, Kempson Way, Suffolk Business Park, Bury St Edmunds, Suffolk. IP32 7AR



01284 757500



01284 703534



sales@sealey.co.uk



www.sealey.co.uk

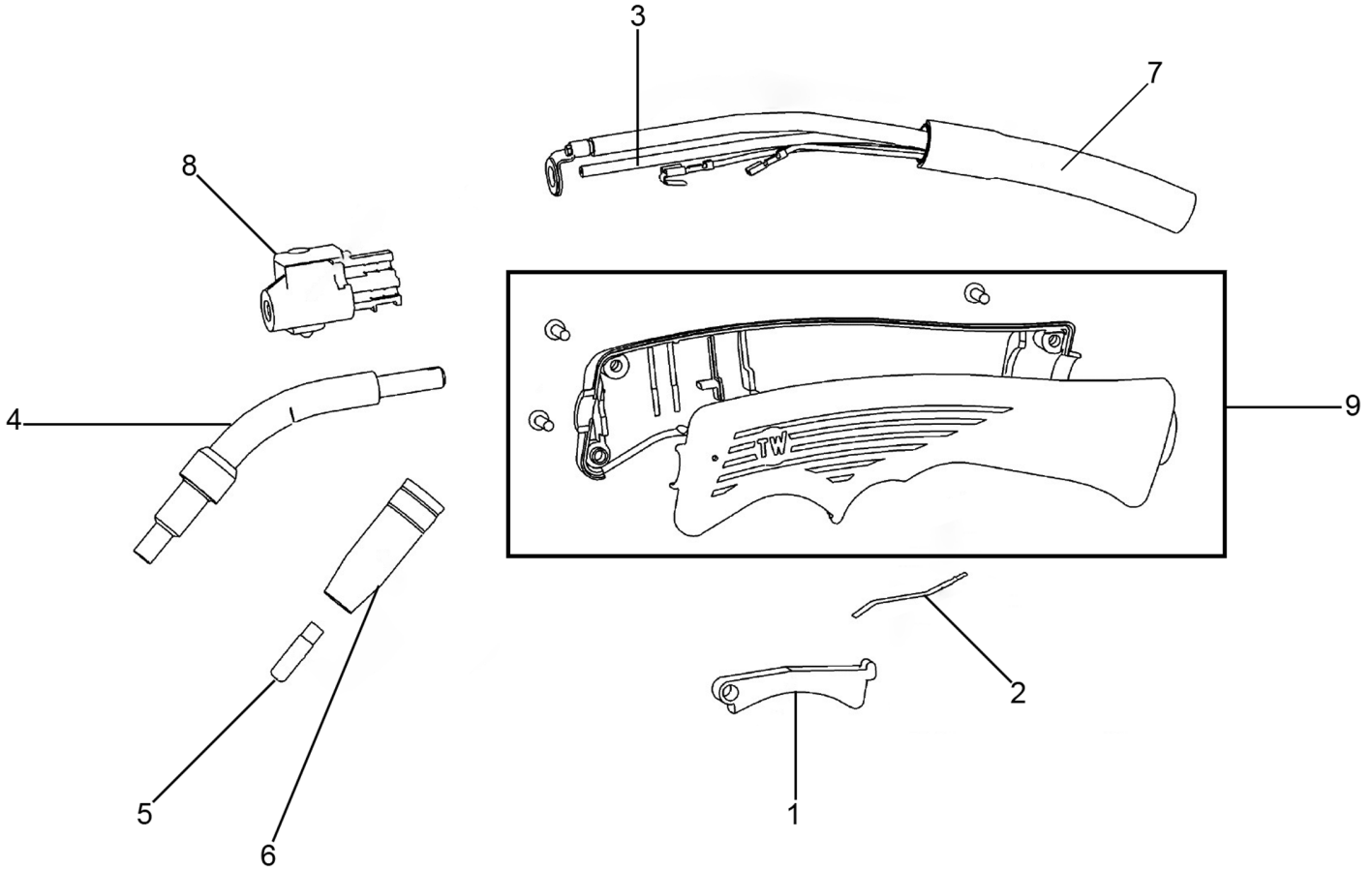

Item	Part No.	Description
1	120/322295	Pushbutton
2	120/452097	Contact Spring
3	120/722050NEV	Liner, White
4	120/722078	Lance (c/w Diffuser)
5	MIG956	Contact Tip 0.6mm (Pack of 5)
6	MIG955	Conical Nozzle (Pack of 3)

Item	Part No.	Description
7	120.990601	Sleeve, Torch Cable
8	120/990464	Torch Connection Assembly
9	120/990465	Handle, Complete
--	168.200162	Spot Welding Nozzle (Not Shown)
--	MIG957	Contact Tip 0.8mm (Pack of 5) (Not Shown)
--	120/742413	Liner, Black (Not Shown)

NOTE: It is our policy to continually improve products and as such we reserve the right to alter data, specifications and component parts without prior notice. There may be alternative versions of this product, please contact us should you require this information.

IMPORTANT: No liability is accepted for incorrect use of product. Spare parts must be fitted by a competent person

WARRANTY: Guarantee is 12 months from purchase date, proof of which will be required for any claim.



Parts Information:
Professional MIG Welder 180Amp 230V
Model No: SUPERMIG180.V2

WIRING DIAGRAM - SUPERMIG180.V2

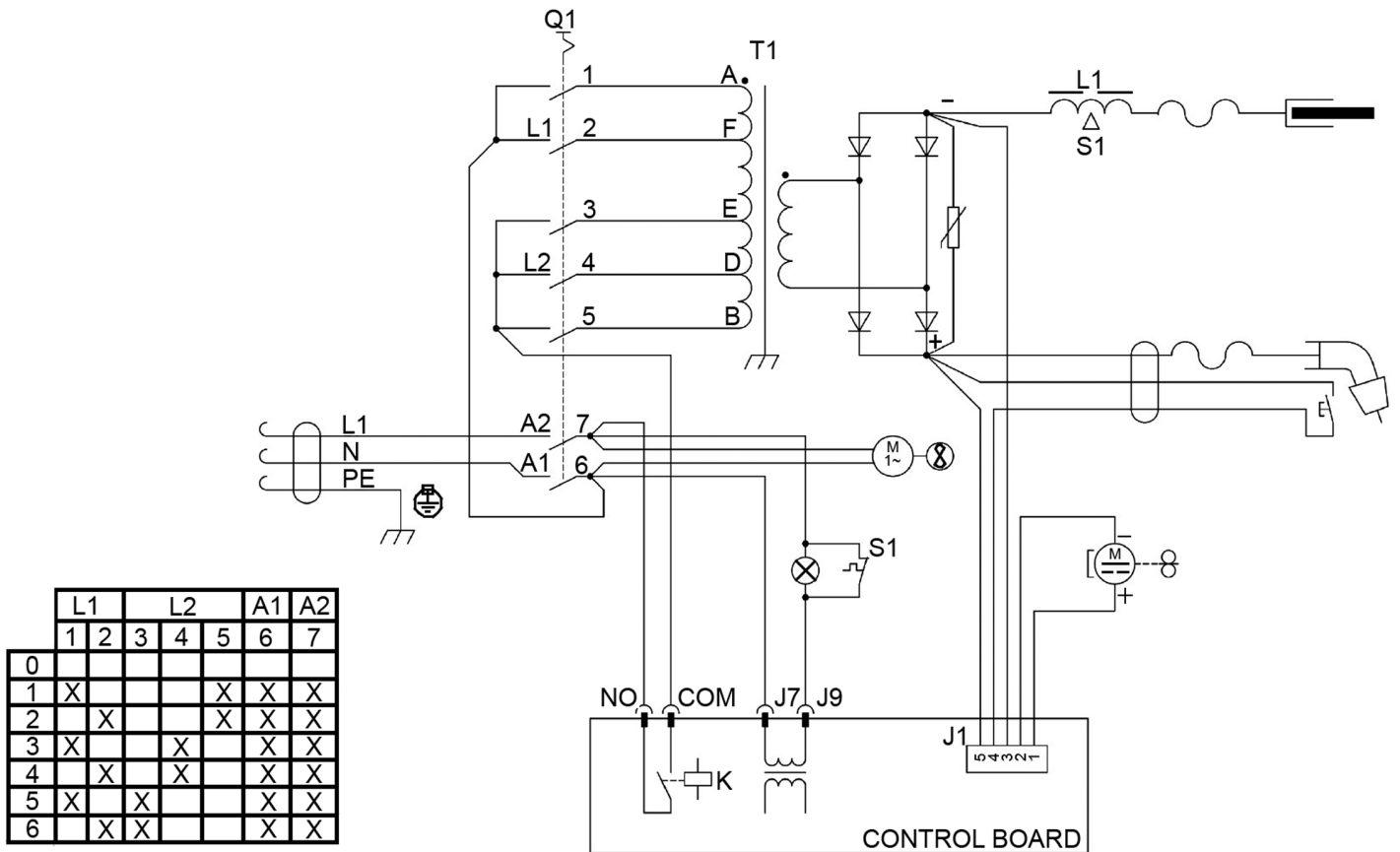

NOTE: It is our policy to continually improve products and as such we reserve the right to alter data, specifications and component parts without prior notice. There may be alternative versions of this product, please contact us should you require this information.

IMPORTANT: No liability is accepted for incorrect use of product. Spare parts must be fitted by a competent person

WARRANTY: Guarantee is 12 months from purchase date, proof of which will be required for any claim.

Sealey Group, Kempson Way, Suffolk Business Park, Bury St Edmunds, Suffolk. IP32 7AR



01284 757500



01284 703534



sales@sealey.co.uk



www.sealey.co.uk