

NOTE: It is our policy to continually improve products and as such we reserve the right to alter data, specifications and component parts without prior notice. There may be alternative versions of this product, please contact us should you require this information.

IMPORTANT: No liability is accepted for incorrect use of product. Spare parts must be fitted by a competent person

WARRANTY: Guarantee is 12 months from purchase date, proof of which will be required for any claim.



Parts Information:
Professional MIG Welder 150Amp 230V
Model No: SUPERMIG150.V2

Item	Part No.	Description
1	120/112079	Potentiometer
2	120.121424	Knob, Potentiometer
3	120/112185	Protection, Rectifier
4	120.980463	PCB, Wire Feed
5	CC10/1	Copper Cable 10mm
6	120.121069	Thermostat 15A 250V
7	120/122400	Switch, White Rocker
8	120/122752	Switch, Rotary
9	MC3CX1.5	Mains Cable
10	120/153900	Wire Feed Motor
11	120.169228	Reactance
12	120.169295	Transformer
13	B/609Z	Bearing
14	120/312025	Blade, Fan
15	120.312356	Handle
16	120.322112	Bushing
17	120/322126	Casing, Feed Roller Shaft
18	120/322127	Casing, Torch Fixing
19	120/322128	Bracket, Counter Roller
20	120/322143	Ring Nut, Cable Protection
21	120/322172	Spindle
22	120/322173	Ring Nut, Reel
23	120/322174	Reel, Thumb Screw
24	120/322193	Wheel
25	120.322631	Frame

Item	Part No.	Description
26	120/422257	Tension Knob, Counter Roller
28	120/452022	Spring
29	120/452056	Spring Catch, Door
32	120/644402	Foot
33	120.644939	Back panel
34	120.644942	Diaphragm
35	120.645088	Bottle holder
36	120.649564	Front panel
37	120.651026	Cover
38	120.644965	Bottom
39	120.655313	Side
40	120.655314	Door
41	120/712001	Clamp, Earth
42	120/722019	Feed Roller
44	120.742901	Mig Torch
45	120/990097	Guide Hose
46	120/990251	Gear Set
47	120/990288	Reel Kit
48	120.990745	Rectifier Kit
49	120/152080	Motor, Electrofan
50	120/322223	Cap, Axle
--	120.482783	Wheels Axle (Not Shown)
--	120/432102	Bull Nose Adaptor (Not Shown)
--	REG/MT	MIG Gas Regulator 2 Gauge Industrial (Not Shown)
--	120.422964	Wheel axle support (Not Shown)

NOTE: It is our policy to continually improve products and as such we reserve the right to alter data, specifications and component parts without prior notice. There may be alternative versions of this product, please contact us should you require this information.

IMPORTANT: No liability is accepted for incorrect use of product. Spare parts must be fitted by a competent person

WARRANTY: Guarantee is 12 months from purchase date, proof of which will be required for any claim.

Sealey Group, Kempson Way, Suffolk Business Park, Bury St Edmunds, Suffolk. IP32 7AR



01284 757500



01284 703534



sales@sealey.co.uk



www.sealey.co.uk

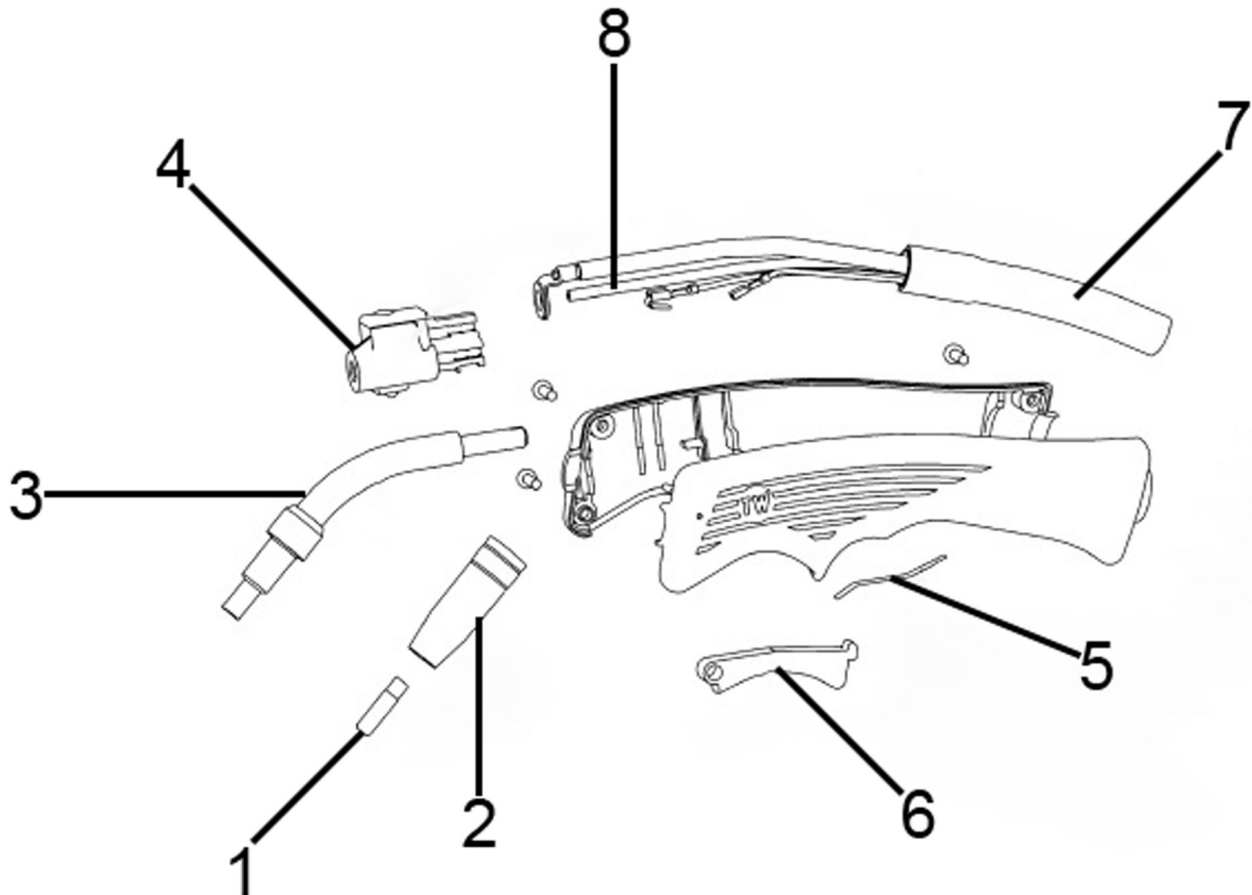

Item	Part No.	Description
1	MIG957	Contact Tip 0.8mm (Pack of 5)
2	MIG955	Conical Nozzle (Pack of 3)
3	120/722078	Lance (c/w Diffuser)
4	120/990464	Torch Connection Assembly

Item	Part No.	Description
5	120/452097	Contact Spring
6	120/322295	Pushbutton
7	120/990600	Sleeve (c/w Cable)
8	120/742412	Liner

NOTE: It is our policy to continually improve products and as such we reserve the right to alter data, specifications and component parts without prior notice. There may be alternative versions of this product, please contact us should you require this information.

IMPORTANT: No liability is accepted for incorrect use of product. Spare parts must be fitted by a competent person

WARRANTY: Guarantee is 12 months from purchase date, proof of which will be required for any claim.

WIRING DIAGRAM

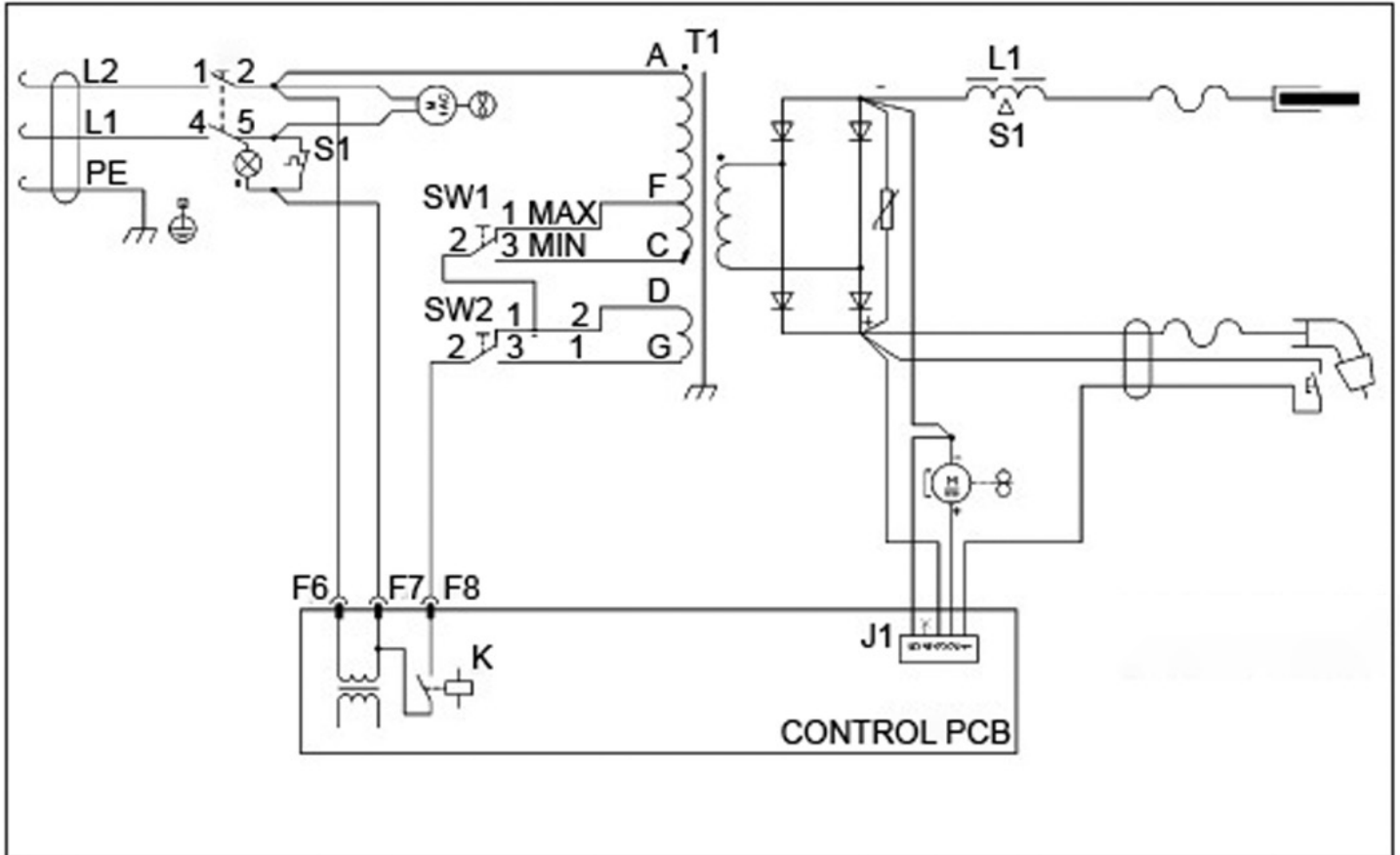

NOTE: It is our policy to continually improve products and as such we reserve the right to alter data, specifications and component parts without prior notice. There may be alternative versions of this product, please contact us should you require this information.

IMPORTANT: No liability is accepted for incorrect use of product. Spare parts must be fitted by a competent person

WARRANTY: Guarantee is 12 months from purchase date, proof of which will be required for any claim.