

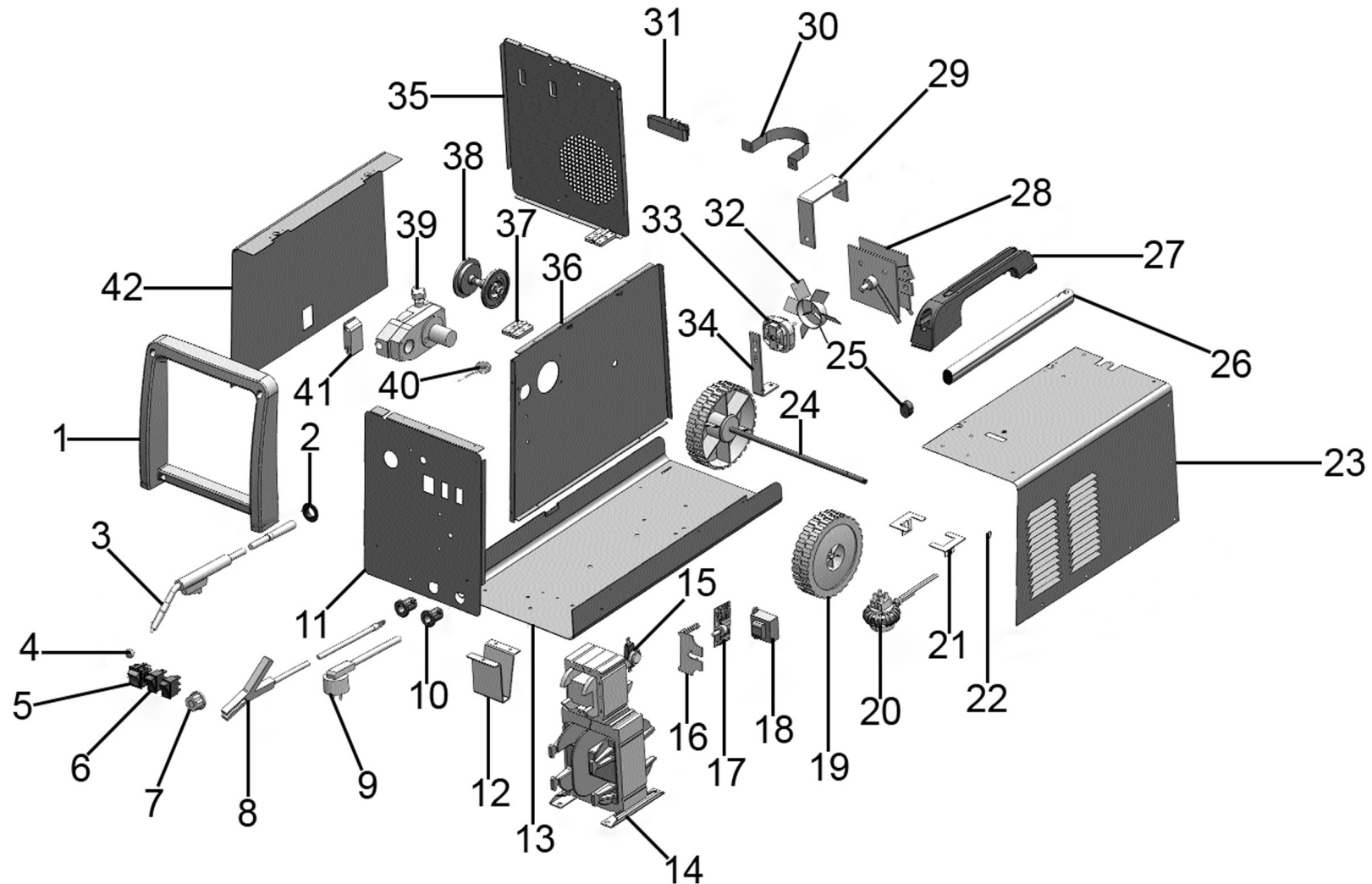

Parts Information:  
MIG Welder 140A 230V  
Model No: SUPERMIG140.V2



**NOTE:** It is our policy to continually improve products and as such we reserve the right to alter data, specifications and component parts without prior notice.

There may be alternative versions of this product, please contact us should you require this information.

**IMPORTANT:** No liability is accepted for incorrect use of product. Spare parts must be fitted by a competent person

**WARRANTY:** Guarantee is 12 months from purchase date, proof of which will be required for any claim.

Sealey Group, Kempson Way, Suffolk Business Park, Bury St Edmunds, Suffolk. IP32 7AR



01284 757500



01284 703534



sales@sealey.co.uk



www.sealey.co.uk



Parts Information:  
**MIG Welder 140A 230V**  
**Model No: SUPERMIG140.V2**

Item	Part No.	Description
1	SMIG140.01	Plastic Frame
2	SMIG150.V3-07	Torch Holder
3	SMIG140.03	Torch Assembly
4	SMIG140.04	Indicator
5	M/MIG150.18	Switch, Rocker
6	SMIG150.V3-10	Switch, Rocker (High/Low)
7	PMIG6035S.W25	Knob, Potentiometer
8	SMIG150.V3-12	Grounding Cable
9	SMIG140.09	Power Cord
10	250XTD.28	Cable Holder
11	SMIG140-V2-11	Front Panel
12	SMIG140.12	Support, Front Feet
13	SMIG140.13	Back Panel
14	SMIG140.14	Main Transformer
15	SMIG140.15	Relay
16	SMIG150.V3-17	Support, PCB
17	SMIG150.V3-18	PCB
18	SMIG150.V3-19	Control Transformer
19	SMIG140.19	Wheel, Fixed
20	SMIG140.20	EMC
21	SMIG140.21	Holder, Wheel Axle
22	SG2303.V2-20	Circlip

Item	Part No.	Description
23	SMIG140-V2-23	Side Panel, Right
24	SMIG140.24	Wheel Axle
25	SMIG140.25	Cover
26	SMIG140.26	Handle
27	SMIG140.27	Handle Frame
28	SMIG140.28	Rectifier
29	SMIG150.V3-32	Bracket, Rectifier
30	SMIG140.30	Holder, Gas Bottle
31	SMIG140.31	Fastening Belt
32	SMIG140.32	Fan Blade
33	SMIG150.V3-22	Fan Motor
34	SMIG150.V3-21	Bracket, Fan
35	SMIG140.35	Back Panel
36	SMIG140.36	Middle Board
37	SMIG275.12	Hinge
38	SMIG150.V3-37	Spool Holder
39	SMIG150.V3-38	Wire Feeder
40	SMIG140.40	Wire Feed EMC
41	SMIG140.41	Door Lock
42	SMIG140-V2-42	Side Panel, Left
--	MSC48.S	Csk Phillips Machine Screw M4 x 8mm (Not Shown)

**NOTE:** It is our policy to continually improve products and as such we reserve the right to alter data, specifications and component parts without prior notice. There may be alternative versions of this product, please contact us should you require this information.

**IMPORTANT:** No liability is accepted for incorrect use of product. Spare parts must be fitted by a competent person

**WARRANTY:** Guarantee is 12 months from purchase date, proof of which will be required for any claim.

Sealey Group, Kempson Way, Suffolk Business Park, Bury St Edmunds, Suffolk. IP32 7AR



01284 757500



01284 703534



sales@sealey.co.uk



www.sealey.co.uk

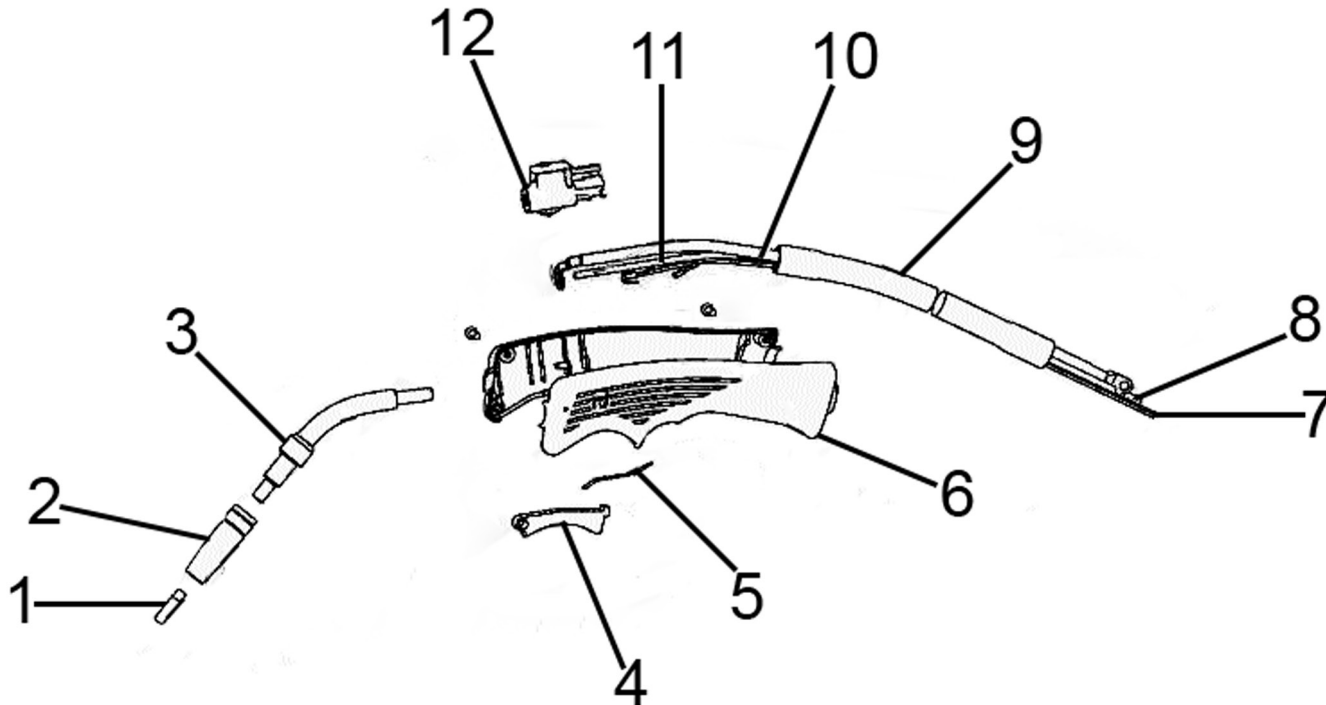

Item	Part No.	Description
1	MIG956	Contact Tip 0.6mm (Pack of 5)
2	MIG955	Conical Nozzle (Pack of 3)
3	SMIG150.V3-8C	Swan Neck
4	SMIG150.V3-8D	Lever, Contact Switch
5	SMIG150.V3-8E	Switch, Contact Plate
6	S0771.27-6	Handle, Torch

Item	Part No.	Description
7	SMIG150.V3-8G	Control Cable
8	SMIG150.V3-8H	Gas Hose
9	SMIG150.V3-8I	Protection Tube
10	SMIG150.V3-8J	Main Cable
11	SMIG150.V3-8K	Liner
12	120/990464	Torch Connection Assembly

**NOTE:** It is our policy to continually improve products and as such we reserve the right to alter data, specifications and component parts without prior notice. There may be alternative versions of this product, please contact us should you require this information.

**IMPORTANT:** No liability is accepted for incorrect use of product. Spare parts must be fitted by a competent person

**WARRANTY:** Guarantee is 12 months from purchase date, proof of which will be required for any claim.