

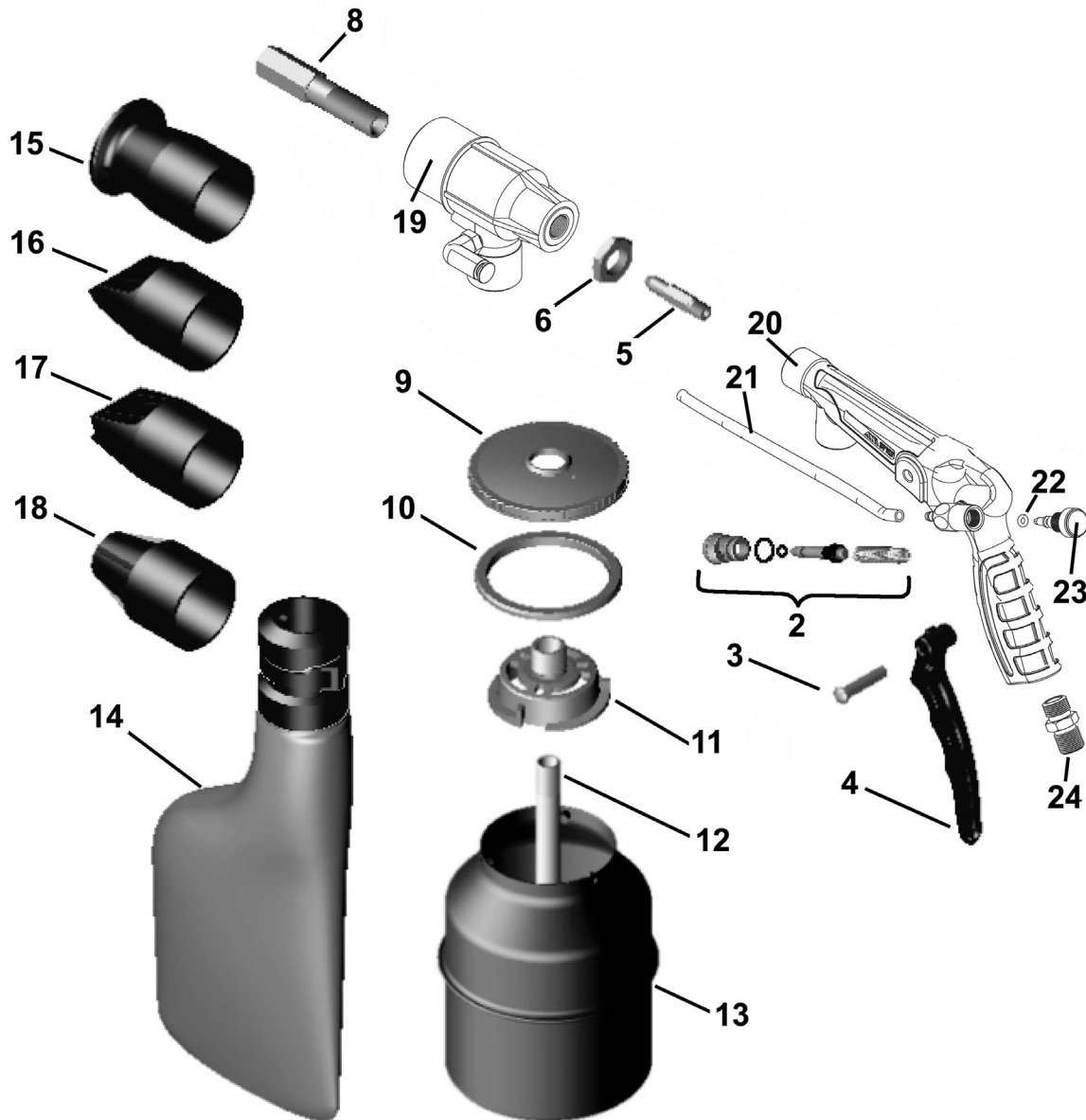

Parts Information:
Recirculating Sand Blasting Kit Extra-Heavy-Duty
Model No: SG12.V2



Item	Part No.	Description
2	142/BH058042	Air Valve Assembly
3	142/BF078138	Rivet
4	142/BE078250	Trigger
5	142/BT098008	Internal Nozzle
6	142/BT098236	Lock Nut
8	142/BT098007	External Nozzle
9	142/BU078137	Pot Lid
10	142/BB078203	Gasket, Lid
11	142/BU078159	Pot Retainer
12	142/BT078160	Pick-Up Tube
13	142/BL078116	Tank

Item	Part No.	Description
14	142/BH098618	Sand Return Bag
15	142/BE098233	Rubber Nozzle
16	142/BE098026	Adaptor, Internal Angle
17	142/BE098027	Adaptor, External Angle
18	142/BE098028	Adaptor, Plain
19	142/BH098774	Housing
20	142/BH098773	Handle Body
21	142.BU098902	Tube
22	142/BD058010	O-Ring
23	142/BS098896	Screw, Air Adjusting
24	142/BS018046	Connection

NOTE: It is our policy to continually improve products and as such we reserve the right to alter data, specifications and component parts without prior notice. There may be alternative versions of this product, please contact us should you require this information.

IMPORTANT: No liability is accepted for incorrect use of product. Spare parts must be fitted by a competent person

WARRANTY: Guarantee is 12 months from purchase date, proof of which will be required for any claim.

Sealey Group, Kempson Way, Suffolk Business Park, Bury St Edmunds, Suffolk. IP32 7AR



01284 757500



01284 703534



sales@sealey.co.uk



www.sealey.co.uk