

SERVICE200

SERVICE250

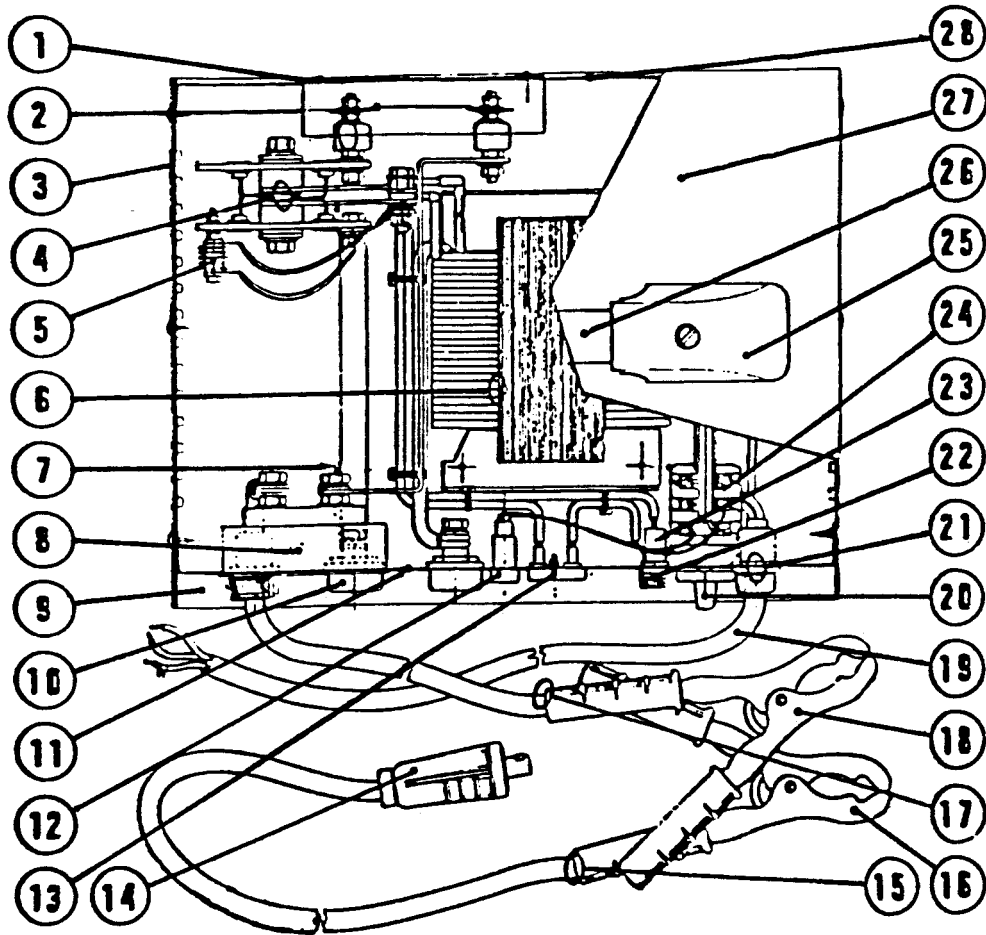

Schema elettrico - Schema électrique - Diagram - Schaltplan - Esquema de conexiones

	R	R	S	S	S	S		
	1	2	3	4	5	6		
POS 1		X	X					45 SINISTRA
POS 0								0 CENTRALE
POS 2	X						X	45 DESTRA
POS 3		X					X	90 DESTRA
POS 4	X				X			135 DESTRA
POS 5		X			X			180 DESTRA
POS 6		X	X					225 DESTRA

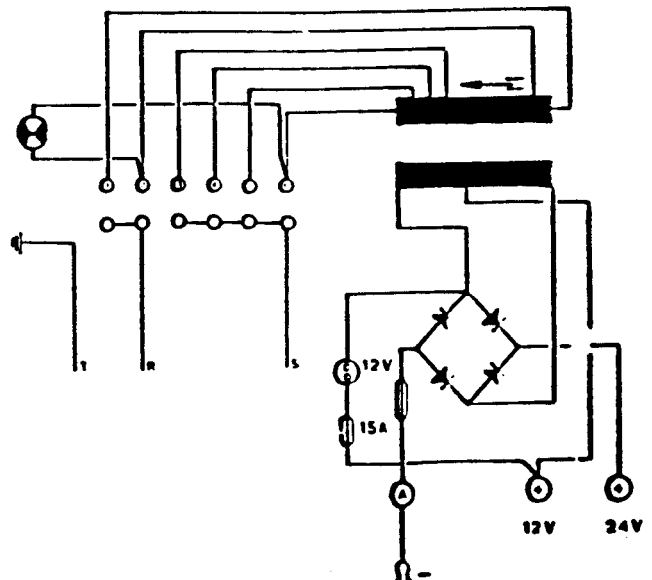

REF	SPARE PARTS LIST	SERVICE	SERVICE
		200	250
		CODE	
1	MALE FUSE COVER	650037	650037
2	FUSE	122450	122452
3	INSULATION PIECE FOR FUSE	990011	990011
4	RECTIFIER	<i>2-PLATE</i> 112144	112146
5	PROTECTION FOR RECTIFIER	112116	112116
6	TRANSFORMER	<i>164482</i> 164381	164348
7	COMPLETE RUBBER FOOT	323001	323001
8	AMMETER	152062	152062
9	CHASSIS	650036	650036
10	DINSE CONNECTION	712035	712035
11	DASH BOARD	614038	614038
12	PILOT LAMP	122447	122447
13	PLUG LIGHT	122451	122451
14	DINSE PLUG	712039	712039
15	CABLE FOR POSITIVE CHARGE PINCERS	123323	123323

REF	SPARE PARTS LIST	SERVICE	SERVICE
		200	250
		CODE	
16	POSITIVE CHARGE PINCERS	712085	712085
17	CABLE FOR NEGATIVE CHARGE PINCERS	123322	123322
18	NEGATIVE CHARGE PINCERS	712028	712028
19	PRIMARY CABLE	132136	132138
20	KONB FOR SWITCH	122058	122058
21	PRESSCABLE	990046	990046
22	FUSE HOLDER	122273	122273
23	FUSE FOR PLUG LIGHT	122449	122449
24	SWITCH WITH SCREW	122448	122448
25	HANDLE SUPPORT	312190	312190
26	HANDLE	644564	644564
27	COVER	650022	650022
28	BACK	650021	650021
	ELECTRIC DIAGRAM	F07018	F07018
	COMPLETE MACHINE	807120	807121