

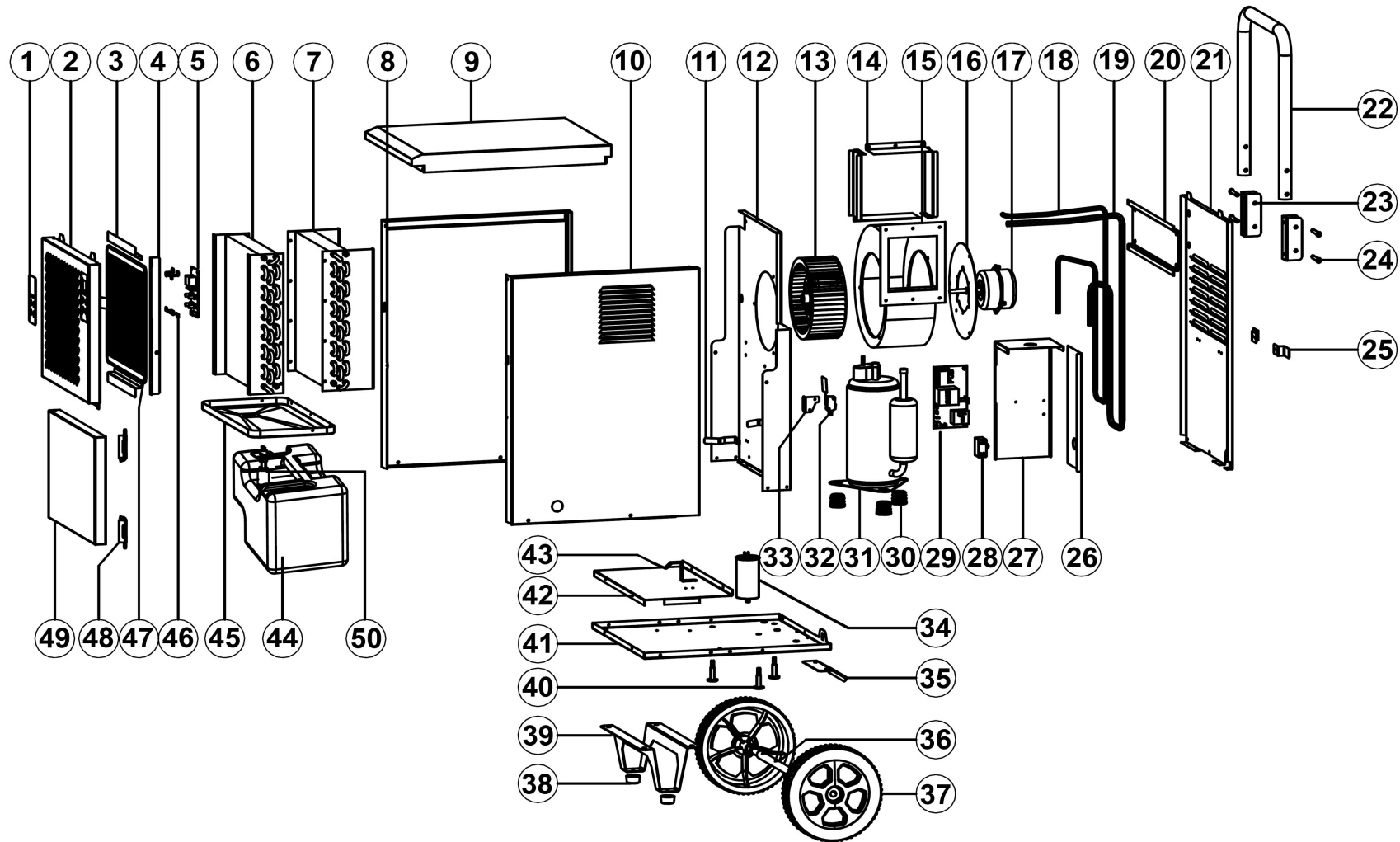

Parts Information:
Industrial Dehumidifier 50L
Model No: SDH50.V3



NOTE: It is our policy to continually improve products and as such we reserve the right to alter data, specifications and component parts without prior notice.

There may be alternative versions of this product, please contact us should you require this information.

IMPORTANT: No liability is accepted for incorrect use of product. Spare parts must be fitted by a competent person

WARRANTY: Guarantee is 12 months from purchase date, proof of which will be required for any claim.

Sealey Group, Kempson Way, Suffolk Business Park, Bury St Edmunds, Suffolk. IP32 7AR



01284 757500



01284 703534



sales@sealey.co.uk



www.sealey.co.uk



Parts Information:
Industrial Dehumidifier 50L
Model No: SDH50.V3

Item	Part No.	Description
1	SDH50.V3-01	Control Panel
2	SDH50.V3-02	Front Panel
3	SDH50.V3-03	Front Panel Bracket (Vertical)
4	SDH50.V3-04	Front Panel Bracket (Horizontal)
5	SDH50.V3-05	Display Board 220V 50Hz
6	SDH50.V3-06A	Evaporator/Condenser Assembly
8	SDH50.V3-08	Side Panel, Left
9	SDH50.V3-09	Top Cover
10	SDH50.V3-10	Side Panel, Right
11	SDH50.V3-11	Water Tank Support Bracket (Left)
12	SDH50.V3-12	Middle Panel
13	SDH50.V3-13	Fan Ø170 x 71mm
14	SDH50.V3-14	Fan Cover Bracket
15	SDH50.V3-15	Fan Cover
16	SDH50.V3-16	Motor Support Bracket
17	SDH50.V3-17	Motor 25W 220V 50Hz
18	SDH50.V3-18	High Pressure Pipe
19	SDH50.V3-19	Low Pressure Pipe
20	SDH50.V3-20	Rear Frame Bracket
21	SDH50.V3-21	Rear Panel
22	SDH50.V3-22	Handle
23	SDH50.V3-23	Handle Bracket
24	SS635.S	Hex Head Set Screw M6 X 35 Zinc
25	SDH50.V3-25	Cable Grip
26	SDH50.V3-26	Control Box Cover
27	SDH50.V3-27	Control Box

Item	Part No.	Description
28	SDH50.V3-28	Motor Capacitance 1.2uF 450V 50Hz
29	SDH50.V3-29	PCB (220-240V 50Hz)
30	SDH50.V3-30	Compressor Foot (Rubber)
31	SDH50.V3-31	Compressor (220-240V 50Hz R290)
32	SDH50.V3-32	Magnetic Switch
33	SDH50.V3-33	Magnetic Switch Bracket
34	SDH50.V3-34	Compressor Capacitor 25uF 450V
35	SDH50.V3-35	Foot Pedal
36	SDH50.V3-36	Wheel Axle
37	SDH50.V3-37	Wheel Ø197mm
38	SDH50.V3-38	Foot
39	SDH50.V3-39	Steel Stand
40	SS840.S	Hex Head Set Screw M8 X 40 Zinc
41	SDH50.V3-41	Bottom Plate
42	SDH50.V3-42	Support Plate
43	SDH50.V3-43	Water Tank Support Bracket (Right)
44	SDH50.V3-44	Water Level Switch
45	SDH50.V3-45	Water Tank
46	SDH50.V3-46	Water Tray
47	SDH50.V3-47	Display Board Bracket
48	SDH50.V3-48	Module Bracket
49	SDH50.V3-49	Temperature/Humidity Sensor
50	SDH50.V3-50	Module Cover
51	SDH50.V3-51	Filter Screen
52	SDH50.V3-52	Hinge for Water Tank Panel
53	SDH50.V3-53	Water Tank Panel

NOTE: It is our policy to continually improve products and as such we reserve the right to alter data, specifications and component parts without prior notice. There may be alternative versions of this product, please contact us should you require this information.

IMPORTANT: No liability is accepted for incorrect use of product. Spare parts must be fitted by a competent person

WARRANTY: Guarantee is 12 months from purchase date, proof of which will be required for any claim.

Sealey Group, Kempson Way, Suffolk Business Park, Bury St Edmunds, Suffolk. IP32 7AR



01284 757500



01284 703534



sales@sealey.co.uk



www.sealey.co.uk