

Parts Information: Crane 1tonne Long Reach Extendable Legs Model No: SC10LR

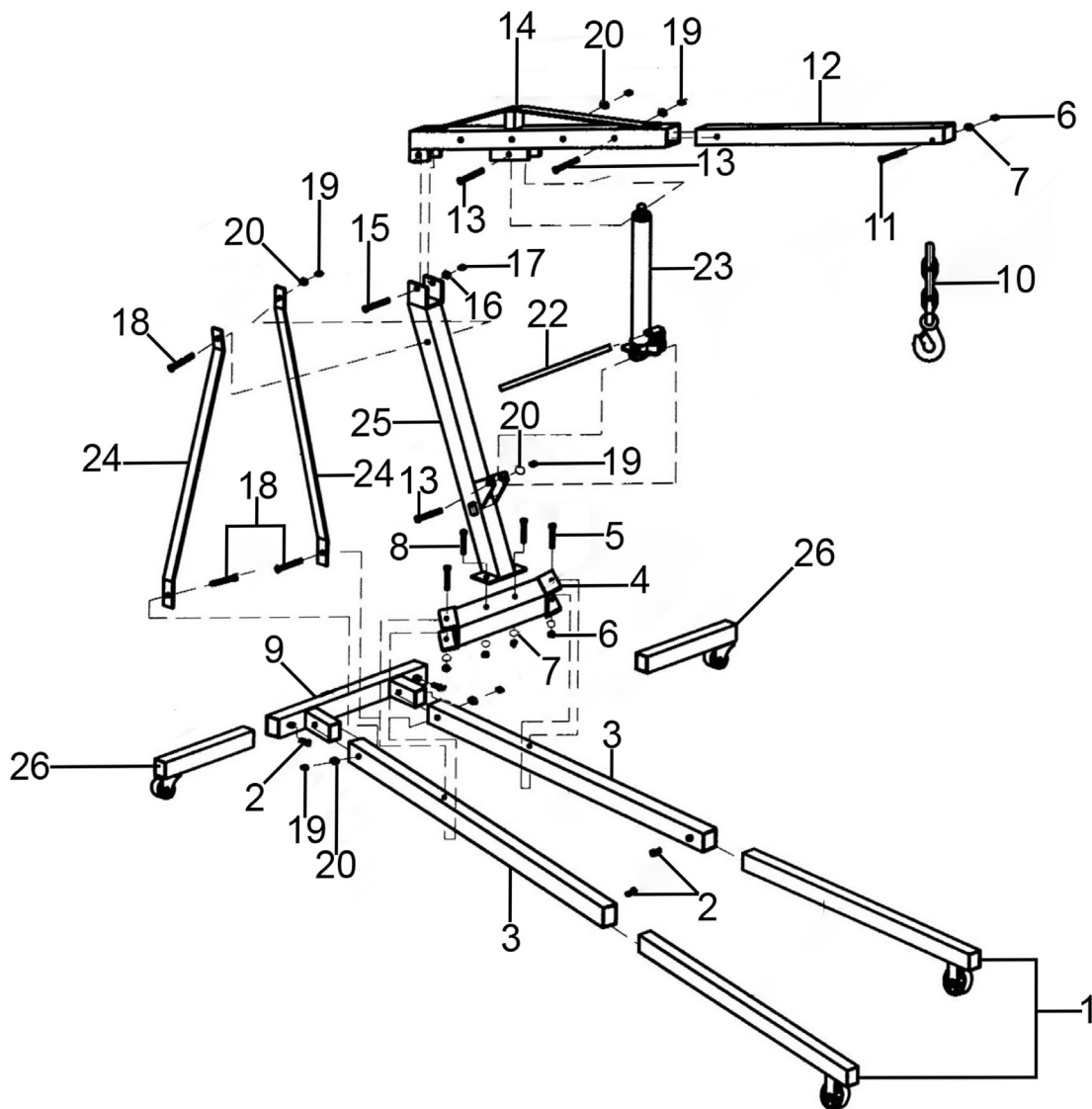

Item	Part No.	Description
1	SC10LR.01	Extension Leg, Front (c/w Wheel)
2	SC10LR.02	Bolt M14 x 30mm
3	SC10LR.03	Leg
4	SC10LR.04	Brace, Main Post
5	HHB14110.SB	Hex Head Bolt M14 x 110mm Black
6	SN14.S	Steel Nut M14
7	FWM14.S	Flat Washer M14
8	SC10LR.08	Bolt M14 x 100mm
9	SC10LR.09	Frame Base
10	SC10LR.10	Hook & Chain Assembly
11	HHB1480.SB	Hex Head Bolt M14 x 80mm Black
12	SC10LR.12	Extension, Jib
13	HHB1690.SB	Hex Head Bolt M16 x 90mm Black

Item	Part No.	Description
14	SC10LR.14	Main Jib
15	SC10LR.15	Bolt M18 x 110mm
16	SN18.SB	Steel Nut M18
17	SWM18.S	Spring Washer M18
18	HHB16100.SB	Hex Head Bolt M16 x 100mm
19	SN16.SB	Steel Nut M16 Black
20	FWM16.S	Flat Washer M16
22	SC10LR.22	Pumping Handle
23	SC10LR.23	Hydraulic Unit
24	SC10LR.24	Strut
25	SC10LR.25	Post, Main Support
26	SC10LR.26	Extension Leg, Rear (c/w Wheel)
--	PH20.V4-21	Wheel, Swivel Castor (Not Shown)

NOTE: It is our policy to continually improve products and as such we reserve the right to alter data, specifications and component parts without prior notice. There may be alternative versions of this product, please contact us should you require this information.

IMPORTANT: No liability is accepted for incorrect use of product. Spare parts must be fitted by a competent person

WARRANTY: Guarantee is 12 months from purchase date, proof of which will be required for any claim.