

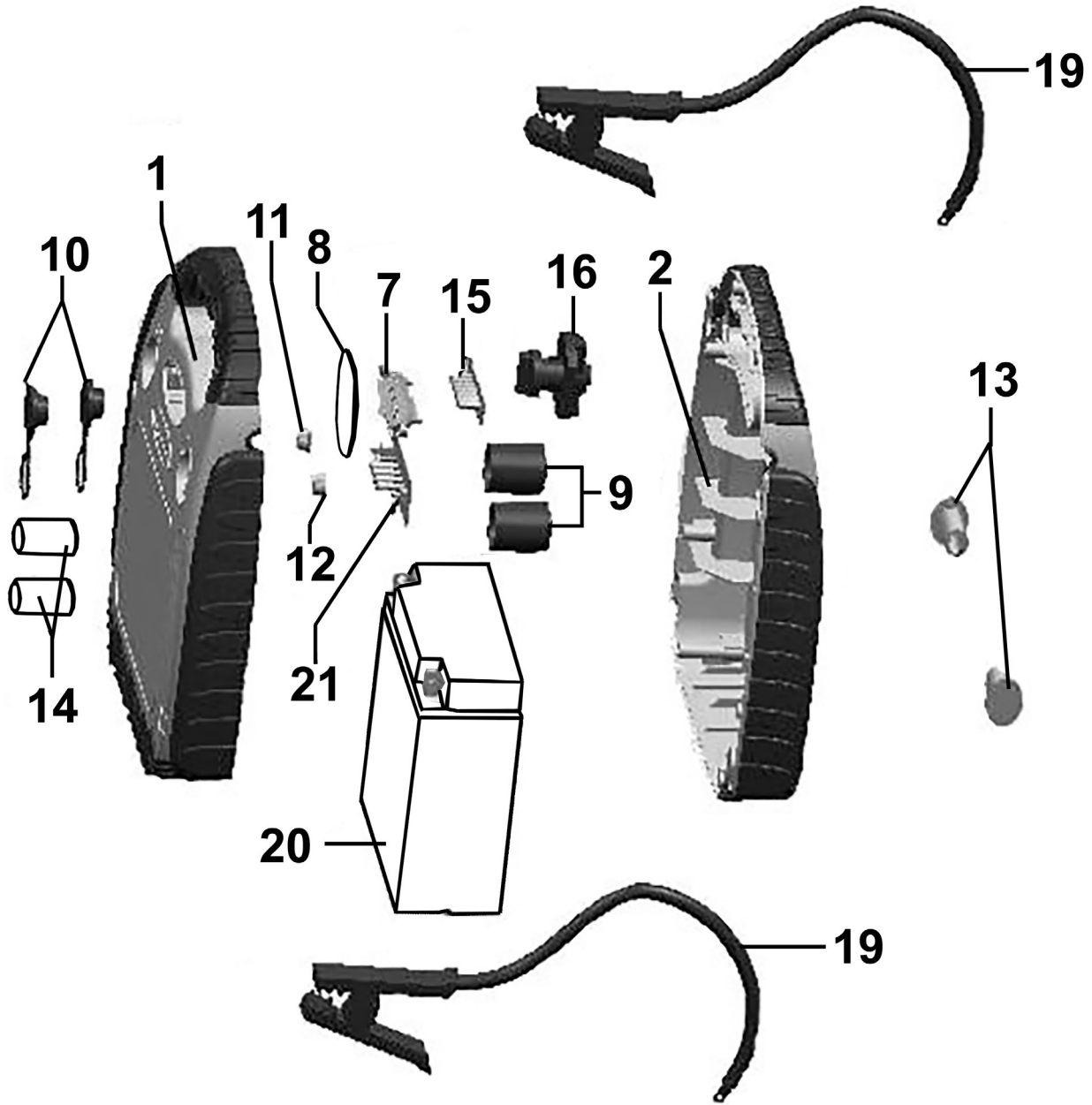

Parts Information:
RoadStart® Emergency Power Pack 12V
900 Peak Amps
Model No: RS131.V6



Item	Part No.	Description
1	RS132.V4-01	Front Case
2	RS132.V4-02	Back Case
7	RS1312HV.07	Reflector
8	RS1312HV.08	Light Cover
9	RS1312HV.09	Fixing Cover For Socket
40	RS1312HV.10	Waterproof Cover For Switch
11	RS1312HV.11	Light Button
12	RS1312HV.12	Test Button
13	RS1312HV.13	Clamp Holder
14	RS1312HV.14	Socket 12v 15a

Item	Part No.	Description
15	RS1312HV.15	Led Assy
16	RS1312HV.16	Safety Switch
19	RS1312HV.19A	Cable (Positive- Assy Inc Clamp)
19	RS1312HV.19B	Cable (Negative- Assy inc Clamp)
20	RS1312HV.20	Battery,12v, 17ah (Lead Acid)(H:160 W:180 B:65) (6-FM-17)
21	RS1312HV.21	PCB, Circuit Board, 120 X 35, c/w LED & Micro Switch
--	RS1312HVC	Mains Charger UK 15V DC 800mA 5mm Pin Jack (Not Shown)

NOTE: It is our policy to continually improve products and as such we reserve the right to alter data, specifications and component parts without prior notice. There may be alternative versions of this product, please contact us should you require this information.

IMPORTANT: No liability is accepted for incorrect use of product. Spare parts must be fitted by a competent person

WARRANTY: Guarantee is 12 months from purchase date, proof of which will be required for any claim.

Sealey Group, Kempson Way, Suffolk Business Park, Bury St Edmunds, Suffolk. IP32 7AR



01284 757500



sales@sealey.co.uk



www.sealey.co.uk