

SEALEY

POWER PRODUCTS

PARTS LIST FOR:
WET & DRY VACUUM CLEANER
Model: **PC205**

Issue No: 1
Date Modified: 200503

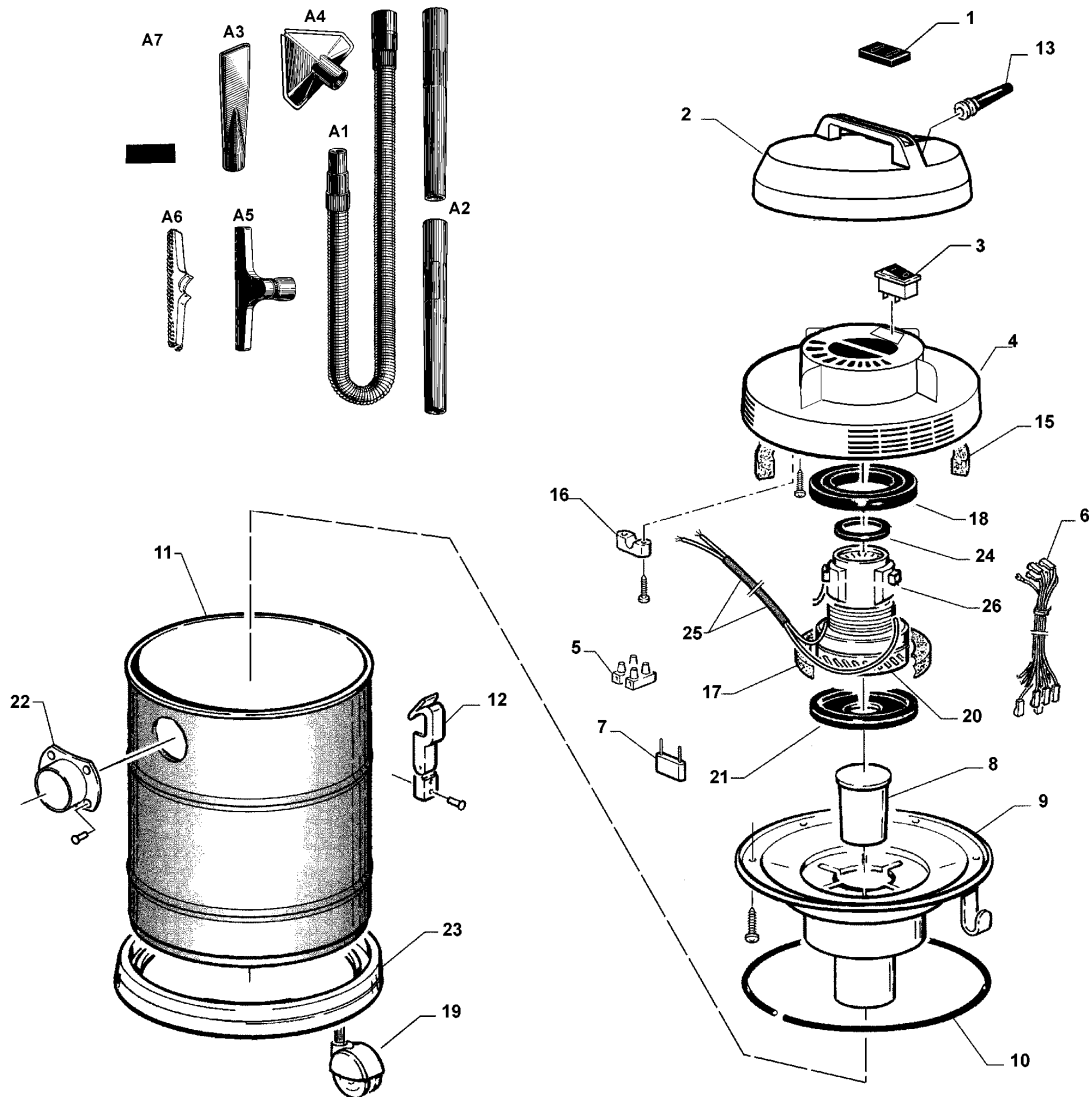

Item	Part No.	Description
1	186/70018B0N	Rubber switch cover
2	186/50186B0C	Cap
3	186/80037B0X	Bipolar Switch
4	186/50200B0C	Motor Cover
5	186/80030Z01	Bipolar terminal box
6	186/80097B0V	Set of wires
7	186/80021B0X	Anti-jamming filter (noise reduction)
8	186/50077B0V	Float
9	186/50064B0R	Motor support
10	186/70016B0N	Round sponge rubber Ø5mm
11	186/10080B6M	Container (20ltr)
12	186/01016B0N	Complete hinge
13	186/50036Z0N	Cable guide
14	186/80046B0N	Feeder
15	186/83102BCN	Filter grill
16	186/50078Z0X	Cable fastener
17	186/83020B8X	Silencer ring

Item	Part No.	Description
18	186/70055B0N	Diaphragm seal
19	186/30085B0X	Rotating wheel
20	186/20060B0X	1000W motor
21	186/70032B0N	Lower motor seal
22	186/50079B0N	Air inlet connection
23	186/50122B6R	Round trolley
24	186/70062B0N	Upper motor absorber
25	186/60235BHN	Black plastic tube Ø 6 x 9mm
26	186/80051B5X	Brush holder insert
A1	186/01317B0N	Flex. Tube for vacuum cleaner Ø 45mm
A2	186/50091B0N	Polypropylene rigid extension Ø 45mm
A3	186/50080B0N	Crevice nozzle Ø 45mm
A4	186/50089B0N	Waste nozzle Ø 45mm
A5	186/60277B0N	Multiuse brush Ø 45mm
A6	186/60280B0N	Black ABS carpets insert
A7	186/83035BHB	Foam filter for use with wet vacuum (optional)

SEALEY POWER PRODUCTS

Sole UK Distributor,
Sealey Group,
Bury St. Edmunds, Suffolk.

01284 757500

01284 703534

sales@sealey.co.uk

www.sealey.co.uk