

NATIONAL MACHINERY

PARTS LIST & DIAGRAM FOR: FOLDING CRANE Model: NC10.V3 (ASSEMBLY)

Issue No: 01
Issued Date: 210906

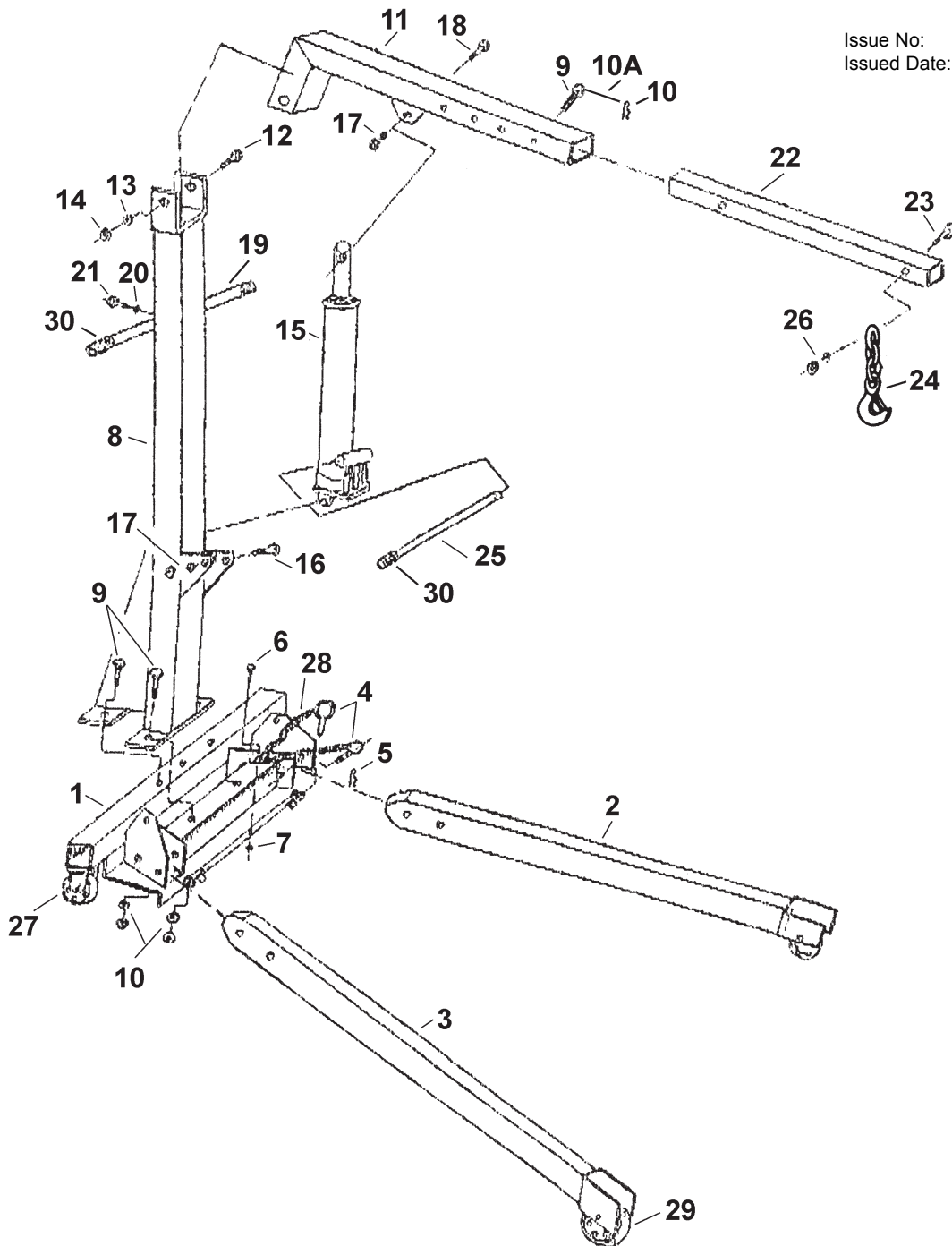

Item	Part No.	Description
1	NC10.V2-01	Base
2	NC10.V2-02	Left Leg
3	NC10.V2-03	Right Leg
4	NC10.V2-04	Lock Pin
5	NC10.V2-05	Split Pin
6	NC10.V2-06	Bolt, M6 x 30
7	NC10.V2-07	Nut, M6
8	NC10.V2-08	Main Support Post
9	NC10.V2-09	Pin
10	NC10.V2-10	Safety Clip
11	NC10.V2-11	Boom

Item	Part No.	Description
12	NC10.V2-12	Bolt, M16 x 100
13	NC10.V2-13	Washer, M16
14	NC10.V2-14	Nut, M16
15	NC10.V2-15	Ram Unit, 3 Tonne
16	NC10.V2-16	Bolt, M16 x 90
17	NC10.V2-17	Nut & Washer, M16
18	NC10.V2-18	Bolt, M16 x 80
19	NC10.V2-19	Handle
20	NC10.V2-20	Washer, M6
21	NC10.V2-21	Bolt, M8 x 20
22	NC10.V2-22	Boom Extension

Item	Part No.	Description
23	NC10.V2-23	Bolt, M12 x 90
24	NC10.V2-24	Hook & Chain
25	NC10.V2-25	Jack Handle
26	NC10.V2-26	Nut & Washer, M12
27	PH20/07	3.5" Swivel Castor
28	NC10.V2-28	Chain
29	NC10.V2-29	5" Rigid Wheel
30	NC10.V2-30	Handle Grip

NOTE: It is our policy to continually improve products and as such we reserve the right to alter data, specifications and component parts without prior notice.
IMPORTANT: No liability is accepted for incorrect use of this product.

Issue No: 1
 Issue Date: 210906

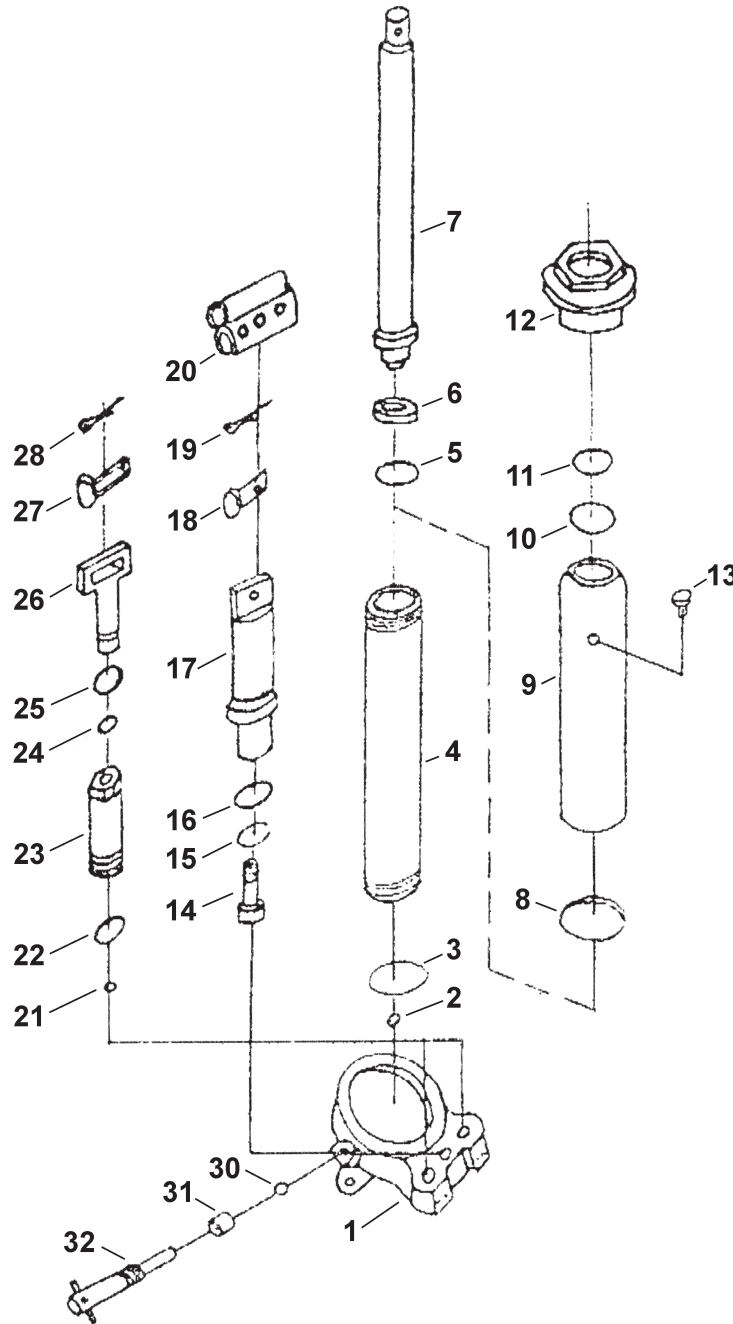

Item	Part No.	Description	Item	Part No.	Description	Item	Part No.	Description
1	NC10.V2-15-01	Ram Base	12	NC10.V2-15-12	Tank Nut	23	NC10.V2-15-23	Pump Cylinder
2	NC10.V2-15-02	Copper Ball	13*	NC10.V2-15-13	Oil Plug	24*	NC10.V2-15-24	O-ring
3	NC10.V2-15-03	Washer	14	NC10.V2-15-14	Screw	25*	NC10.V2-15-25	Back-up Ring
4	NC10.V2-15-04	Cylinder	15	NC10.V2-15-15	Spring Washer	26	NC10.V2-15-26	Plunger
5*	NC10.V2-15-05	O-ring	16	NC10.V2-15-16	Washer	27	NC10.V2-15-27	Plunger Pin
6*	NC10.V2-15-06	Ram Seal Washer	17	NC10.V2-15-17	Stand	28	NC10.V2-15-28	Cotter Pin
7	NC10.V2-15-07	Ram	18	NC10.V2-15-18	Pin	30	NC10.V2-15-30	Steel Ball
8*	NC10.V2-15-08	Seal Ring	19	NC10.V2-15-19	Cotter Pin	31*	NC10.V2-15-31	Seal Ring
9	NC10.V2-15-09	Oil Tank	20	NC10.V2-15-20	Handle Socket	32	NC10.V2-15-32	Release Screw
10*	NC10.V2-15-10	Sealing Gasket	21	NC10.V2-15-21	Steel Ball	-	NC10.V2-RK	Repair Kit (consists of items marked *)
11*	NC10.V2-15-11	O-ring	22	NC10.V2-15-22	Washer			

NOTE: It is our policy to continually improve products and as such we reserve the right to alter data, specifications and component parts without prior notice.
IMPORTANT: No liability is accepted for incorrect use of this product.