

## LIFT ASSEMBLY

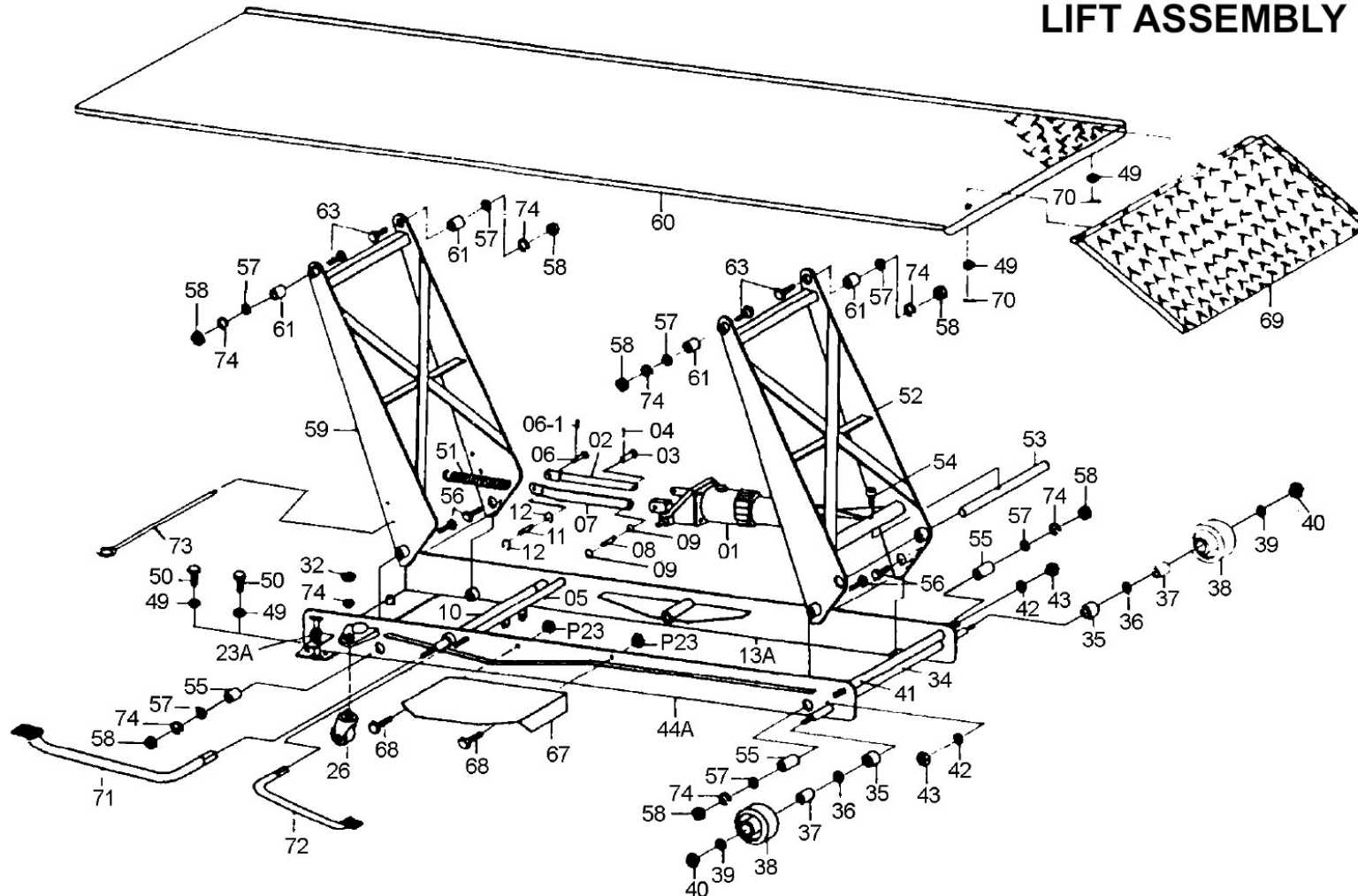

**NOTE:** It is our policy to continually improve products and as such we reserve the right to alter data, specifications and component parts without prior notice.

There may be alternative versions of this product, please contact us should you require this information.

**IMPORTANT:** No liability is accepted for incorrect use of product. Spare parts must be fitted by a competent person

**WARRANTY:** Guarantee is 12 months from purchase date, proof of which will be required for any claim.

Sealey Group, Kempson Way, Suffolk Business Park, Bury St Edmunds, Suffolk. IP32 7AR



01284 757500



01284 703534



sales@sealey.co.uk



www.sealey.co.uk



Parts Information:  
**Mini Tractor Lift Yankee 400kg Hydraulic**  
**Model No: MT400**

Item	Part No.	Description
1	MC400/001	Pump assy 9" wide hyd mc400 & mt40
2	MC400/002	Link
3	MC400/003	Pin
4	MC400/004	Pin
5	MC400/005	Spindle
6	MC400/006	Pin
6-1	MC400/006-1	Clip
7	MC400/007	Link
8	MC400/008	Pin
9	MC400/009	Snap-ring
10	MC400/010	Spindle
11	MC400/011	Pin
12	MC400/012	Snap ring
13A	MC400/013A	Frame,right hand kit
23A	MC400/023A	Adjusting screws assembly
26	MC400/026	Castor fork assembly
32	MT400/032	Nut m12 x 1.5 fine pitch black
34	MC400/034	Spindle
35	MC400/035	Spacing collar
36	MC400/036	Washer
37	MC400/037	Bush,front wheel
38	MC400/038	Front wheel
39	MC400/039	Washer
40	MC400/040	M20 half hex nut
41	MC400/041	Lifting arm stop rod
42	MC400/042	Washer
43	MC400/043	Nut

Item	Part No.	Description
44A	MC400/044A	Frame,left hand kit
49	MC400/049	Washer
50	MC400/050	Bolt
51	MC400/051	Return spring
52	MC400/052	Back Lifting Arm
53	MC400/053	Spindle
54	MC400/054	Pin
55	MC400/055	Bush
56	MT400/056	Bolt, m12x70
57	MC400/057	Washer
58	SN12.S	Steel Nut M12 Zinc
59	MC400/059	Front lifting arm
60	MT400/060	Platform, mt400
61	MC400/061	Bush
63	MT400/063	Bolt m12x40
67	MC400/067	Guarded plate
68	SS825.SB	Hex Head Set Screw M8 X 25 Black
69	MC400/069	Leading plate
70	MC400/070	Cotter pin
71	MC400/071	Foot pedal,lift
72	MC400/072	Foot pedal,release
73	MC400/073	Set spindle
73	MT400/073	Set spindle(long)
74	MT400/074	Washer, spring
P23	SN8.S	Steel Nut M8 Zinc
--	MC400/001A	Pump assembly 15 1/2" wide (Not Shown)

**NOTE:** It is our policy to continually improve products and as such we reserve the right to alter data, specifications and component parts without prior notice. There may be alternative versions of this product, please contact us should you require this information.

**IMPORTANT:** No liability is accepted for incorrect use of product. Spare parts must be fitted by a competent person

**WARRANTY:** Guarantee is 12 months from purchase date, proof of which will be required for any claim.

**Sealey Group**, Kempson Way, Suffolk Business Park, Bury St Edmunds, Suffolk. IP32 7AR



01284 757500



01284 703534



sales@sealey.co.uk



www.sealey.co.uk

## HYDRAULIC PUMP ASSEMBLY

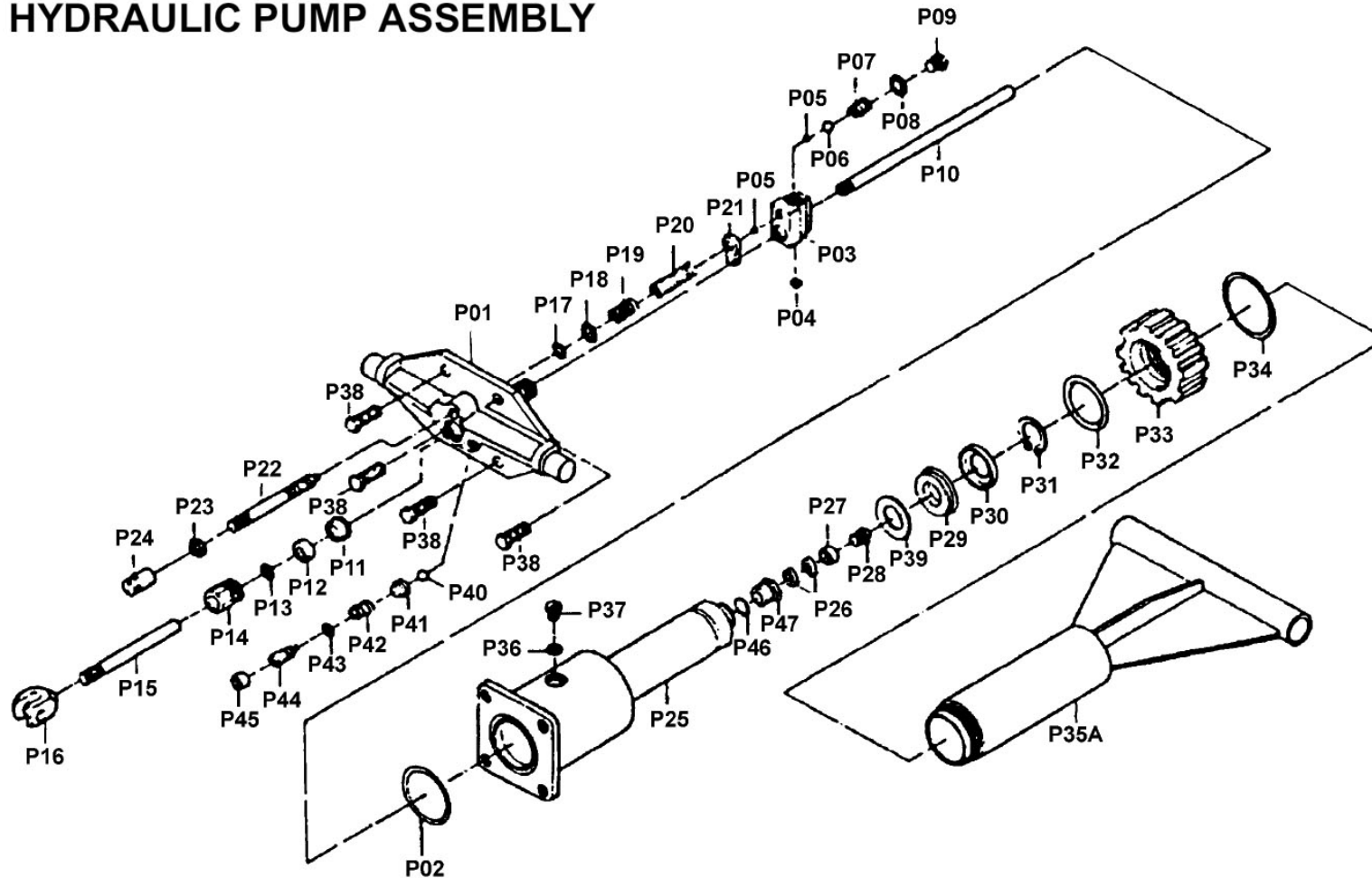

**NOTE:** It is our policy to continually improve products and as such we reserve the right to alter data, specifications and component parts without prior notice.

There may be alternative versions of this product, please contact us should you require this information.

**IMPORTANT:** No liability is accepted for incorrect use of product. Spare parts must be fitted by a competent person

**WARRANTY:** Guarantee is 12 months from purchase date, proof of which will be required for any claim.



Parts Information:  
**Mini Tractor Lift Yankee 400kg Hydraulic**  
**Model No: MT400**

Item	Part No.	Description
P01	MC400/001-P01	Base
P02	MC400/001-P02	Packing
P03	MC400/001-P03	Check Valve
P04	MC400/001-P04	Filter
P05	SB-6.4	Steel Ball 6.4mm
P06	SB-9.5	Steel Ball 9.5mm
P07	MC400/001-P07	Spring
P08	MC400/001-P08	Gasket
P09	MC400/001-P09	Plug
P10	MC400/001-P10	Pipe
P11	MC400/001-P11	U-Seal
P12	MC400/001-P12	Copper Washer
P13	MC400/001-P13	O-Ring
P14	MC400/001-P14	Regulating Plug
P15	MC400/001-P15	Pump Piston
P16	MC400/001-P16	Union Nut
P17	MC400/001-P17	O-Ring
P18	MC400/001-P18	Washer
P19	MC400/001-P19	Spring
P20	MC400/001-P20	Spring
P21	MC400/001-P21	Set Nut
P22	MC400/001-P22	Release Valve
P23	SN8.S	Steel Nut M8 Zinc
P24	MC400/001-P24	Union Nut
P25	MC400/001-P25	Ram

Item	Part No.	Description
P26	MC400/001-P26	Seal
P27	MC400/001-P27	Washer
P28	MC400/001-P28	Plug
P29	MC400/001-P29	Cup Seal
P30	MC400/001-P30	Cap Washer
P31	MC400/001-P31	Circlip
P32	MC400/001-P32	O-Ring
P33	MC400/001-P33	Top Nut
P34	MC400/001-P34	Packing
P35	MC400/001P35A	Mc400/001-P35a Cylinder Assembly
P36	MC400/001-P36	Seal
P37	MC400/001-P37	Air Vent Valve
P38	MC400/001-P38	Bolt M10x30
P39	MC400/001-P39	Back-Up Ring
P40	SB-4.7	Steel ball 4.7mm
P41	MC400/001-P41	Spring
P42	MC400/001-P42	Spring
P43	MC400/001-P43	O-Ring
P44	MC400/001-P44	Screw
P45	MC400/001-P45	Cap
P46	MT400/001-P46	O-Ring
P47	MT400/001-P47	Plug
--	MC400/001-RK	Repair Kit For Hyd Pump Assy (Not Shown)
--	MC400/001-EX	MC400/001-Recon Hydraulic Unit (Not Shown)

**NOTE:** It is our policy to continually improve products and as such we reserve the right to alter data, specifications and component parts without prior notice. There may be alternative versions of this product, please contact us should you require this information.

**IMPORTANT:** No liability is accepted for incorrect use of product. Spare parts must be fitted by a competent person

**WARRANTY:** Guarantee is 12 months from purchase date, proof of which will be required for any claim.

**Sealey Group**, Kempson Way, Suffolk Business Park, Bury St Edmunds, Suffolk. IP32 7AR



01284 757500



01284 703534



sales@sealey.co.uk



www.sealey.co.uk