

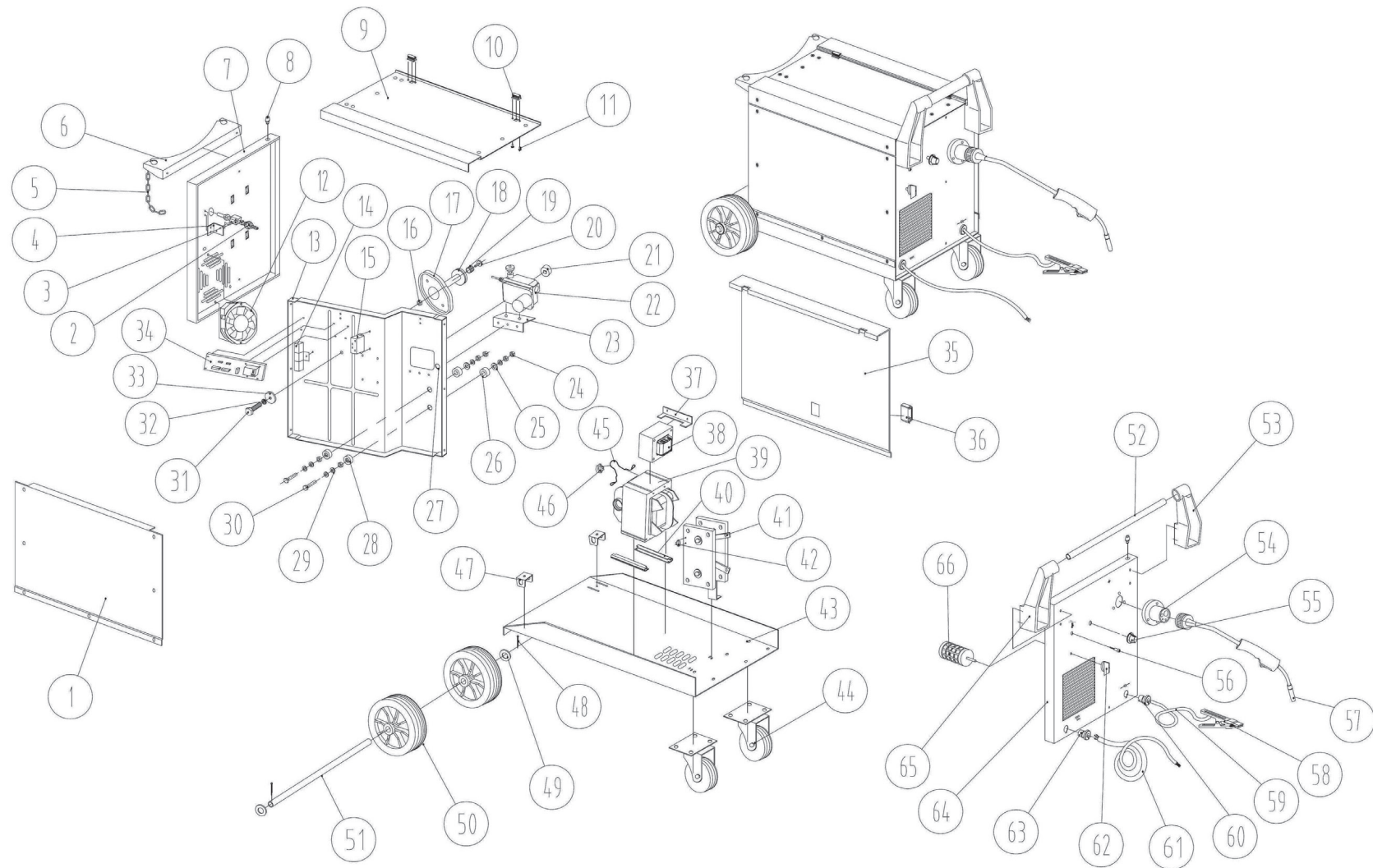

Parts Information:
Professional Gas/No-Gas MIG Welder 170Amp with Euro Torch
Model No: MIGHTYMIG170.V2



NOTE: It is our policy to continually improve products and as such we reserve the right to alter data, specifications and component parts without prior notice.

IMPORTANT: No liability is accepted for incorrect use of product.

WARRANTY: Guarantee is 12 months from purchase date, proof of which will be required for any claim.

Sealey Group, Kempson Way, Suffolk Business Park, Bury St Edmunds, Suffolk. IP32 7AR



01284 757500



01284 703534



sales@sealey.co.uk



www.sealey.co.uk



Parts Information:
**Professional Gas/No-Gas MIG Welder
170Amp with Euro Torch
Model No: MIGHTYMIG170.V2**

Item	Part No.	Description
1	M/MIG210.01	SIDE PANEL
2	M/MIG250.66	VALVE ASSEMBLY
3	M-MIG170V2.03	VALVE CONNECTOR
4	M/MIG210.03	VALVE BRACKET
5	M/MIG210.04	CHAIN
6	M/MIG210.05	GAS BOTTLE SUPPORT
7	M/MIG210.06	BACK PANEL
8	M/MIG210.07	RUBBER SUPPORT
9	M/MIG210.08	TOP PANEL
10	M/MIG210.09A	HINGE (TWO SCREW FIXING)
11	FN8.S	FLANGE NUT SERRATED M8 ZINC (SINGLE)
12	M/MIG250.75	FAN
13	M/MIG170.13	INNER PANEL
14	M/MIG210.14	RESISTANCE
15	M/MIG170.15	RELAY
16	SN10.S	STEEL NUT M10 ZINC DIN934(SINGLE)
17	M/MIG170.17	SPINDLE FOR WIRE REEL
18	M/MIG170.18	KNOB
19	M/MIG170.19	SPRING
20	M/MIG170.20	KNOB (B)
21	SMIG275.52	WIRE FEEDER ROLLER 0.6-0.8mm
22	M/MIG250.66	VALVE ASSEMBLY
23	M/MIG210.26	WIRE FEED SUPPORT
24	SN8.S	STEEL NUT M8 ZINC DIN934 (SINGLE)
25	RW825.S	REPAIR WASHER M8x25 (SINGLE)
26	M/MIG250.36	INSULATING WASHER
27	M/MIG210.30	RUBBER RING
28	M/MIG250.38	INSULATING WASHER
29	RW825.S	REPAIR WASHER M8x25 (SINGLE)
30	M/MIG190.33	BOLT M8X55
31	SS1055.S	HEX HEAD SET SCREW M10x55mm SINGLE
32	SWM10.SB	SPRING WASHER M10 BLACK(SINGLE)
33	FWM10.S	FLAT WASHER M10 SINGLE

Item	Part No.	Description
34	M/MIG170.34	WIRE FEED PCB
35	M/MIG210.37	ACCESS PANEL
36	M/MIG250.73	LATCH
37	M/MIG170.37	FILTER BRACKET
38	M/MIG170.38	FILTER REACTOR
39	M/MIG170.39	TRANSFORMER (SO)
40	M/MIG170.40	TRANSFORMER SUPPORT
41	M/MIG170.41	RECTIFIER
42	M/MIG170.42	SWITCH
43	M/MIG210.44	BOTTOM PANEL
44	M/MIG250.06	WHEEL,CASTOR (75x10x32x116)
45	M/MIG170.45	SWITCH BRACKET
46	M/MIG170.46	THERMAL SWITCH
47	M/MIG210.47	AXLE BRACKET
48	M/MIG250.02	COTTER PIN
49	FWM20.S	FLAT WASHER M20 SINGLE
50	M/MIG250.04	WHEEL,FIXED (200x19x42)
51	M/MIG250.49	AXLE
52	M/MIG250.17	HANDLE
53	M/MIG250.13	HANDLE SUPPORT (RIGHT)
54	M/MIG250.11	TORCH HOLDER ASSEMBLY
55	M/MIG250.20	SPEED CONTROL KNOB
56	M/MIG210.56	OVERLOAD INDICATOR LIGHT, 24V, 24mA
57	M-MIG210V2.58	EURO WELDING TORCH 3mtr - ERGO 15.2
58	M/MIG210.59	CLAMP (EARTH)
59	M/MIG210.60	EARTH CABLE
60	M/MIG170.63	CABLE TIP
61	M/MIG170.61	LINE CABLE
62	M/MIG210.63	VOLTAGE CONTROL KNOB
63	M/MIG170.63	CABLE TIP
64	M/MIG170.64	FRONT PANEL
65	M/MIG250.16	HANDLE SUPPORT (LEFT)
66	M/MIG170.66	VOLTAGE CONTROL SWITCH

NOTE: It is our policy to continually improve products and as such we reserve the right to alter data, specifications and component parts without prior notice.

IMPORTANT: No liability is accepted for incorrect use of product.

WARRANTY: Guarantee is 12 months from purchase date, proof of which will be required for any claim.

Sealey Group, Kempson Way, Suffolk Business Park, Bury St Edmunds, Suffolk. IP32 7AR



01284 757500



01284 703534



sales@sealey.co.uk



www.sealey.co.uk