

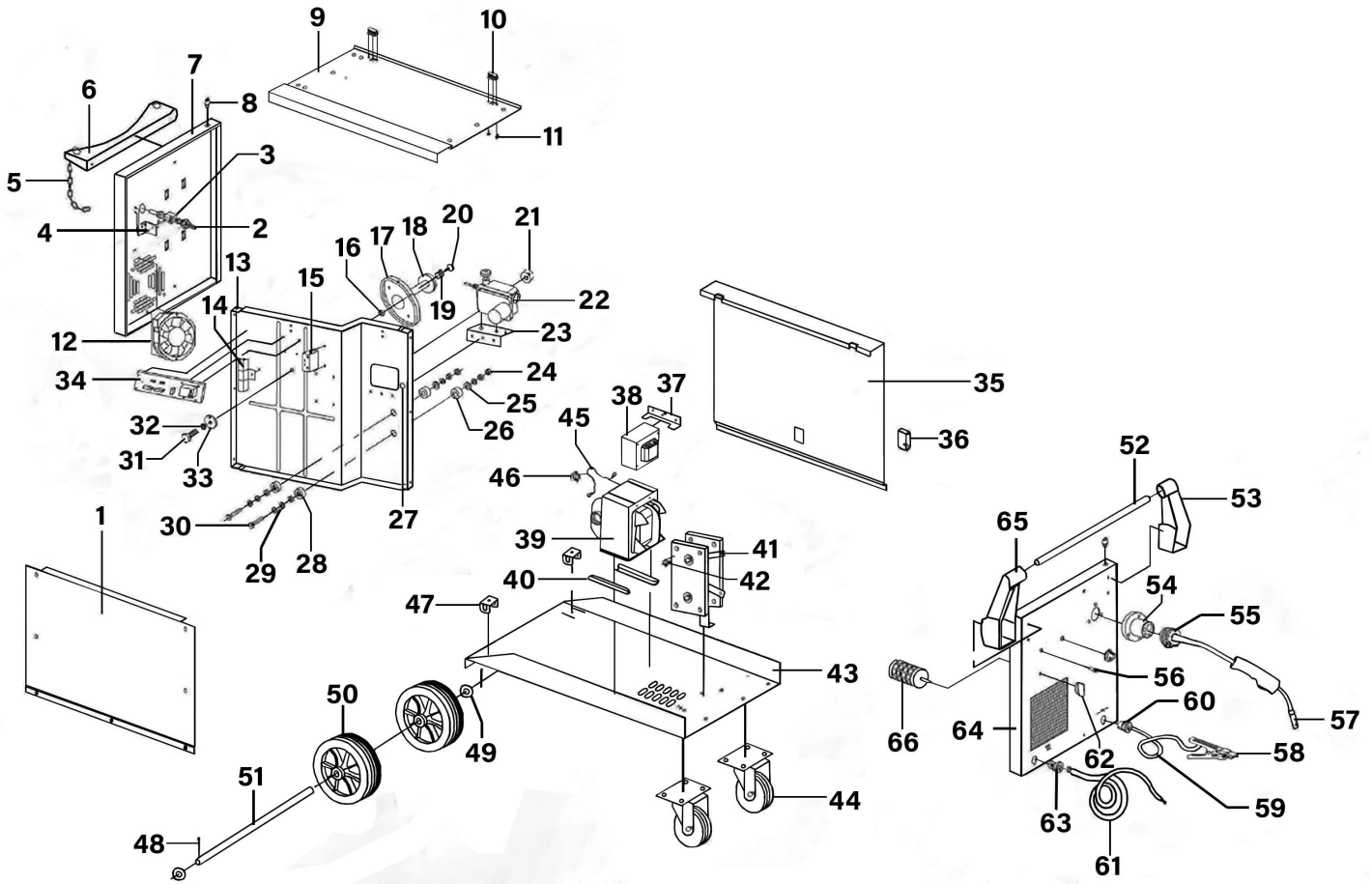

Parts Information:  
**Professional Gas/No-Gas MIG Welder 170A  
 with Euro Torch**  
**Model No: MIGHTYMIG170.V2**



Item	Part No.	Description
1	M/MIG210.01	Side Panel
2	M/MIG250.66	Valve Assembly
3	M-MIG170V2.03	Valve Connector
4	M/MIG210.03	Valve Bracket
5	M/MIG210.04	Chain
6	M/MIG210.05	Gas Bottle Support
7	M/MIG210.06	Back Panel
8	M/MIG210.07	Rubber Support
9	M/MIG210.08	Top Panel
10	M/MIG210.09A	Hinge (Two Screw Fixing)
11	FN8.S	Flange Nut Serrated M8 Zinc
12	M/MIG250.75	Fan
13	M/MIG170.13	Inner Panel
14	M/MIG210.14	Resistance
15	M/MIG170.15	Relay
16	SN10.S	Steel Nut M10 Zinc
17	M/MIG170.17	Spindle For Wire Reel

Item	Part No.	Description
18	M/MIG170.18	Knob, Plastic, OD: 56mm ID: 52mm, 16mm Hex Female Fitting
19	M/MIG170.19	Spring Dia 19.5mm
20	M/MIG170.20	Knob, (B), Plastic, OD: 25mm L: 20mm, 8x14mm Male Fitting
21	SMIG275.52	Wire Feed Roller 0.6-0.8mm
22	M/MIG250.60	Wire Feed Motor (Internal 24v)
23	M/MIG210.26	Wire Feed Support
24	SN8.S	Steel Nut M8 Zinc
25	RW825.S	Repair Washer M8 X 25 Zinc
26	M/MIG250.36	Insulating Washer
27	M/MIG210.30	Rubber Ring
28	M/MIG250.38	Insulating Washer
29	RW825.S	Repair Washer M8 X 25 Zinc
30	M/MIG190.33	Bolt M8x55
31	SS1055.S	Hex Head Set Screw M10 X 55 Zinc
32	SWM10.SB	Spring Washer M10 Black

**NOTE:** It is our policy to continually improve products and as such we reserve the right to alter data, specifications and component parts without prior notice. There may be alternative versions of this product, please contact us should you require this information.

**IMPORTANT:** No liability is accepted for incorrect use of product. Spare parts must be fitted by a competent person

**WARRANTY:** Guarantee is 12 months from purchase date, proof of which will be required for any claim.

Sealey Group, Kempson Way, Suffolk Business Park, Bury St Edmunds, Suffolk. IP32 7AR



01284 757500



sales@sealey.co.uk



www.sealey.co.uk



Parts Information:  
**Professional Gas/No-Gas MIG Welder 170A  
with Euro Torch  
Model No: MIGHTYMIG170.V2**

Item	Part No.	Description
33	FWM10.S	Flat Washer M10 Zinc
34	M/MIG170.34	PCB, Wire Feed Board, 130 x 55mm, 9 Connections
35	M/MIG210.37	Access Panel
36	M/MIG250.73	Latch
37	M/MIG170.37	Filter Bracket
38	M/MIG170.38	Filter Reactor
39	M/MIG170.39	Transformer
40	M/MIG170.40	Transformer Support
41	M/MIG170.41	Rectifier
42	M/MIG170.42	Overload Cut Out Switch
43	M/MIG210.44	Bottom Panel
44	M/MIG250.06	Wheel, Swivel Castor, 4 Bolt (D:75 W:30 B:10 H:115)
45	M/MIG170.45	Bracket For Switch
46	M/MIG170.46	Thermal Cut Out Switch
47	M/MIG210.47	Axle Bracket
48	M/MIG250.02	Cotter Pin 3 x 40
49	FWM20.S	Flat Washer M20

Item	Part No.	Description
50	M/MIG250.04	Wheel, Fixed (D:200 W:50 B: 19)
51	M/MIG250.49	Axle
52	M/MIG250.17	Handle
53	M/MIG250.13	Handle Support (Right)
54	M/MIG250.11	Torch Holder Assembly
55	M/MIG250.20	Knob, Speed Control, Plastic, Knurled, Red Top, OD: 25mm L:
56	M/MIG210.56	Overload Indicator Light, 24v, 24ma
57	M-MIG210V2.58	Euro Welding Torch 3Mtr - Ergo 15.2
58	M/MIG210.59	Clamp (Earth)
59	M/MIG210.60	Earth Cable
60	M/MIG170.63	Cable Grip
61	M/MIG170.61	Line Cable
62	M/MIG210.63	Knob, Voltage Control, OD: 36mm, 6mm Pentagonal Female Fitting
63	M/MIG170.63	Cable Grip
64	M/MIG170.64	Front Panel
65	M/MIG250.16	Handle Support (Left)
66	M/MIG170.66	Switch, Rotary, Voltage Control c/w Knob

**NOTE:** It is our policy to continually improve products and as such we reserve the right to alter data, specifications and component parts without prior notice. There may be alternative versions of this product, please contact us should you require this information.

**IMPORTANT:** No liability is accepted for incorrect use of product. Spare parts must be fitted by a competent person

**WARRANTY:** Guarantee is 12 months from purchase date, proof of which will be required for any claim.

**Sealey Group**, Kempson Way, Suffolk Business Park, Bury St Edmunds, Suffolk. IP32 7AR



01284 757500



sales@sealey.co.uk



www.sealey.co.uk