

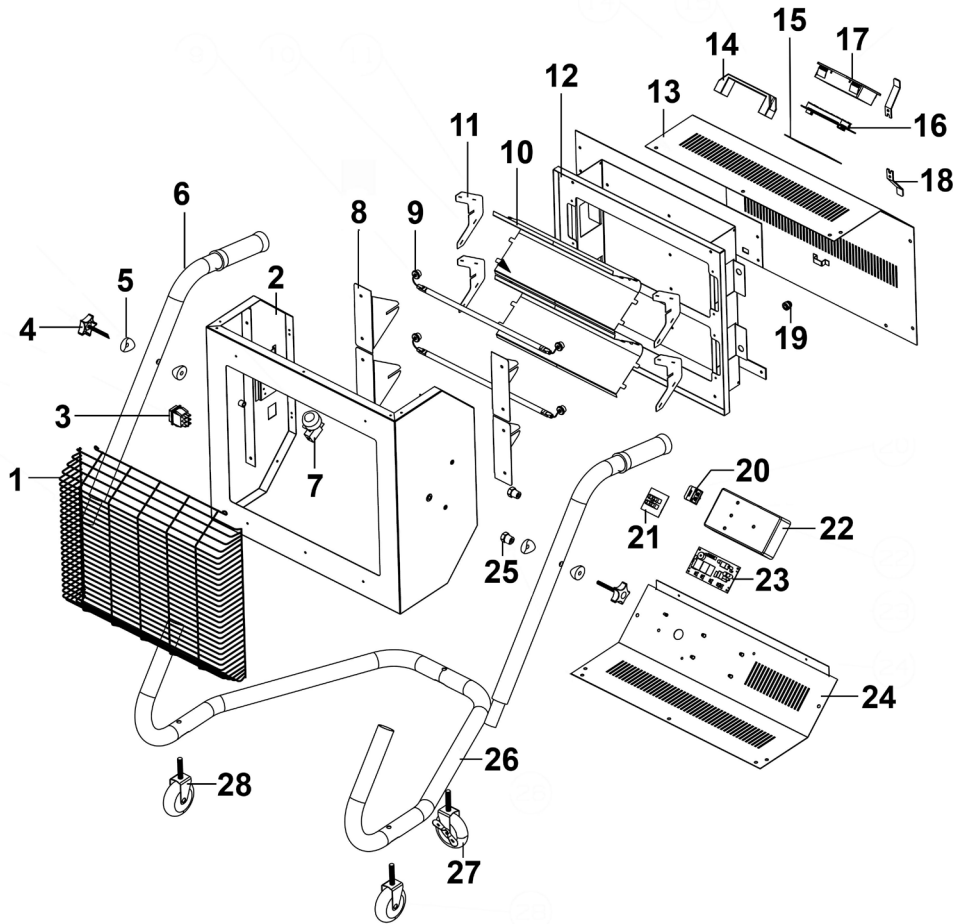

Parts Information:
Infrared Halogen Heater 1.4/2.8kW 230V
Infrared Heater 1.2/2.4kW 110V
Model No: IR15 & IR15110V



Item	Part No.	Description
1	IR15.01	Front Guard
2	IR15.02	Main Body
2	IR15110V.02	Main Body-IR15110V ONLY
3	IR15.03	On/Off Switch
4	IR15.04	Handle Adjustment Knob
5	IR15.05	Plastic Curved Washer
6	IR15.06	Handle
6	IR15110V.06	Handle-IR15110V ONLY
7	IR15.07	Tilt Switch
8	IR15.08	Infrared Lamp Holder
9	IR15.09	Ruby Halogen Infrared Elements 230V
9	IR15110V.09	Ruby Halogen Infrared Elements 110-IR15110V ONLY
10	IR15.10	Reflector
11	IR15.11	Side Plate for Reflector
12	IR15.12	Reflector Plate Base
13	IR15.13	Rear Cover, Upper
13	IR15110V.13	Rear Cover, Upper-IR15110V ONLY

Item	Part No.	Description
14	IR15.14	Rear Handle
15	IR15.15	PCB Base Support
16	IR15.16	PCB (for Upper Unit)
17	IR15.17	PCB Cover (for Upper Unit)
18	IR15.18	Cable Hook
19	IR15.19	Thermocouple Grip
20	IR15.20	Cable Grip
21	IR15.21	Terminal
22	IR15.22	PCB Cover (for Lower Unit)
23	IR15.23	PCB (for Lower Unit)
24	IR15.24	Rear Cover, Lower
24	IR15110V.24	Rear Cover, Lower-IR15110V ONLY
25	IR15.25	Stop Block
26	IR15.26	Stand Base
26	IR15110V.26	Stand Base-IR15110V ONLY
27	IR15.27	Castor Wheel (c/w Brake)
28	IR15.28	Castor Wheel (w/o Brake)

NOTE: It is our policy to continually improve products and as such we reserve the right to alter data, specifications and component parts without prior notice. There may be alternative versions of this product, please contact us should you require this information.

IMPORTANT: No liability is accepted for incorrect use of product. Spare parts must be fitted by a competent person

WARRANTY: Guarantee is 12 months from purchase date, proof of which will be required for any claim.

Sealey Group, Kempson Way, Suffolk Business Park, Bury St Edmunds, Suffolk. IP32 7AR



01284 757500



01284 703534



sales@sealey.co.uk



www.sealey.co.uk