

Parts Information:  
**Composite Air Impact Wrench 3/4" Sq  
 Drive Twin Hammer**  
**Model No: GSA6004**

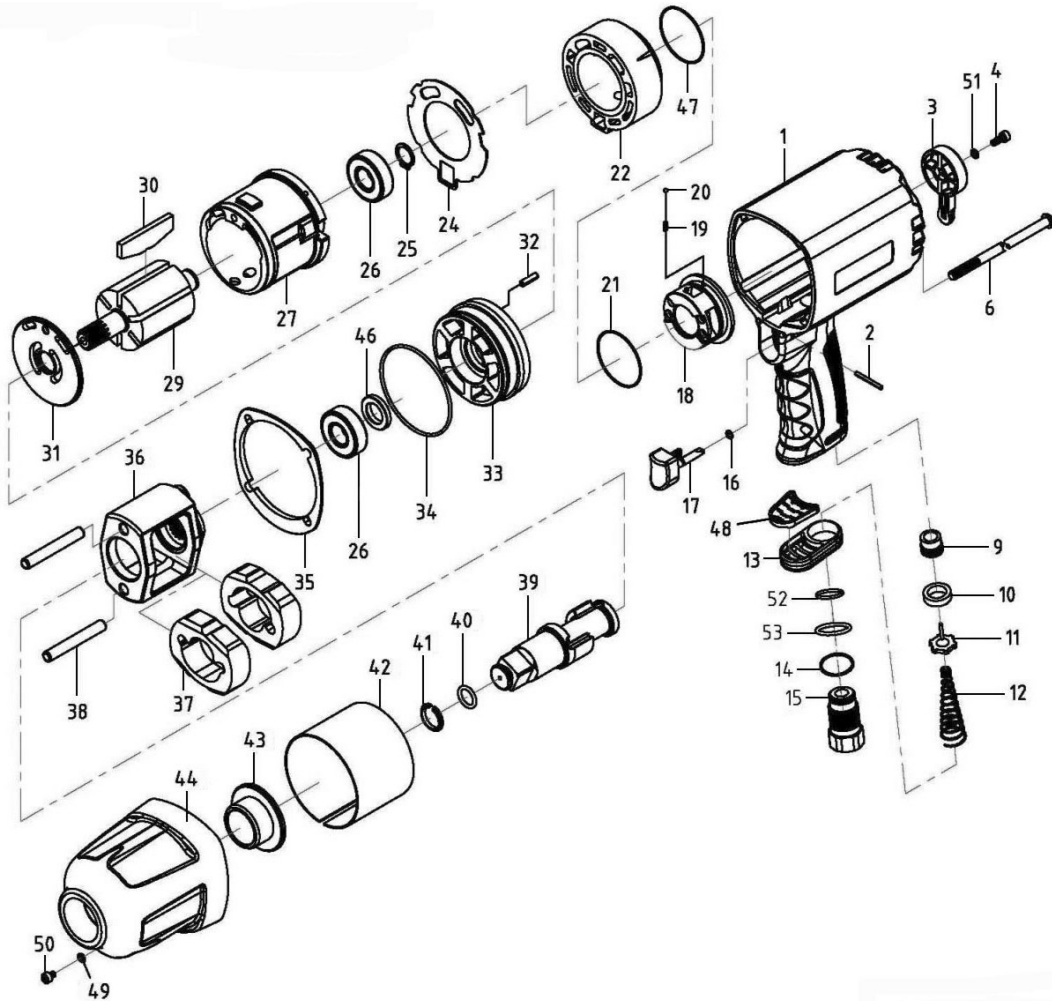

Item	Part No.	Description
1	GSA6004.01	Housing
2	GSA01.05	Spring Pin
3	GSA6004.03	Reverse Switch Knob
4	SCB410.SB	Socket Cap Bolt M4 x 10mm, Black
6	GSA6004.06	Button Head Torx Screw M6 x 114mm
9	GSA6004.09	Lock Screw
10	GSA6004.10	Valve Seat
11	GSA6004.11	Valve
12	GSA6004.12	Valve Spring
13	GSA6004.13	Exhaust Deflector
14	GSA6004.14	Seal Ring Washer
15	GSA6004.15	Air Inlet

Item	Part No.	Description
16	GSA6004.16	O-Ring
17	GSA6004.17	Trigger
18	GSA6004.18	Air Regulator
19	GSA6004.19	Spring
20	SB-2.5	Steel Ball
21	GSA6004.21	O-Ring
22	GSA6004.22	Valve Seat
24	GSA6004.24	Gasket
25	SA58.V2-17	Circlip
26	B/6003Z	Bearing
27	GSA6004.27	Cylinder
29	GSA6004.29	Rotor

**NOTE:** It is our policy to continually improve products and as such we reserve the right to alter data, specifications and component parts without prior notice. There may be alternative versions of this product, please contact us should you require this information.

**IMPORTANT:** No liability is accepted for incorrect use of product. Spare parts must be fitted by a competent person

**WARRANTY:** Guarantee is 12 months from purchase date, proof of which will be required for any claim.



Parts Information:  
**Composite Air Impact Wrench 3/4" Sq  
Drive Twin Hammer  
Model No: GSA6004**

Item	Part No.	Description
30	GSA6004.30	Rotor Blade
31	GSA6004.31	Plate
32	SA604/12	Spring Pin
33	GSA6004.33	End Plate, Front
34	GSA6004.34	O-Ring
35	GSA6004.35	Gasket
36	GSA6004.36	Hammer Cage
37	GSA6004.37	Hammer Dog
38	GSA6004.38	Hammer Pin
39	GSA6004.39	Anvil
40	GSA6004.40	O-Ring
41	GSA6004.41	Retainer

Item	Part No.	Description
42	GSA6004.42	Sleeve
43	GSA6004.43	Anvil Bushing
44	GSA6004.44	Hammer Case
46	GSA6004.46	Oil Seal
47	GSA6004.47	Gasket
48	GSA6004.48	Muffler Cover
49	GSA6004.49	O-Ring
50	SCB510.SB	Socket Cap Bolt M5 x 10mm, Black
51	FWM4.SB	Flat Washer M4, Black
52	GSA6004.52	O-Ring
53	GSA6004.53	Seal

**NOTE:** It is our policy to continually improve products and as such we reserve the right to alter data, specifications and component parts without prior notice. There may be alternative versions of this product, please contact us should you require this information.

**IMPORTANT:** No liability is accepted for incorrect use of product. Spare parts must be fitted by a competent person

**WARRANTY:** Guarantee is 12 months from purchase date, proof of which will be required for any claim.

**Sealey Group**, Kempson Way, Suffolk Business Park, Bury St Edmunds, Suffolk. IP32 7AR



01284 757500



01284 703534



sales@sealey.co.uk



www.sealey.co.uk