

Parts Information:
Air Palm Random Orbital Sander Ø150mm
Dust-Free Self-Contained
Model No: GSA06

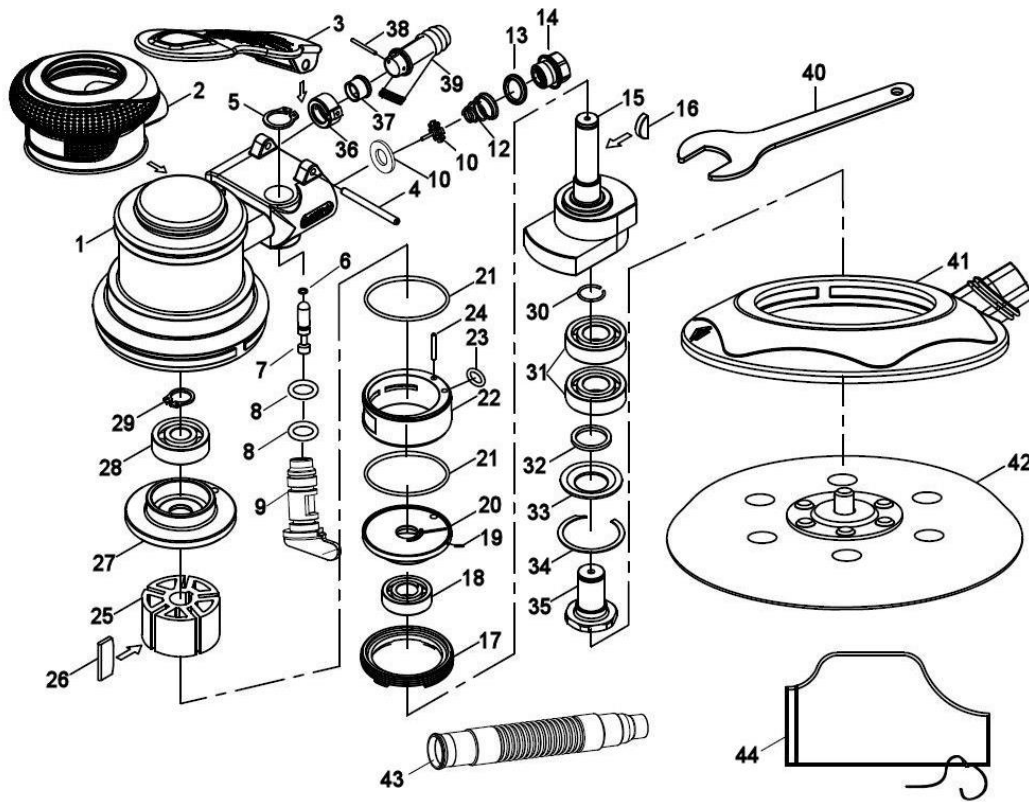

Item	Part No.	Description
1	GSA06.01	HOUSING
2	GSA06.02	JACKET
3	GSA06.03	TRIGGER
4	GSA06.04	SPLIT PIN
5	GSA06.05	SNAP RING
6	GSA06.06	O-RING
7	GSA06.07	PIN
8	GSA06.08	O-RING
9	GSA06.09	VALVE KNOB
10	GSA06.11	SWITCH VALVE
12	GSA06.12	SPRING
13	GSA06.13	EJECTOR BUSHING
14	GSA06.14	AIR INLET CONNECTOR
15	GSA06.15	DRIVE SHAFT
16	GSA06.16	WOODRUFF KEY
17	GSA06.17	LOCK NUT
18	B/6001ZZ	BEARING 6001ZZ
19	GSA06.19	STRAIGHT PIN
20	GSA06.20	FRONT CYLINDER HEAD
21	GSA06.21	O-RING
22	GSA06.22	CYLINDER
23	GSA06.23	O-RING

Item	Part No.	Description
24	GSA06.24	SPLIT PIN
25	GSA06.25	ROTOR
26	GSA06.26	BLADE
27	GSA06.27	BACK CYLINDER HEAD
28	B/6000ZZ	BEARING 6000ZZ
29	GSA06.29	SNAP RING
30	GSA06.30	E STOPPER
31	B/6001ZZ	BEARING 6001ZZ
32	GSA06.32	SEALING RING
33	GSA06.33	V GASKET
34	GSA06.34	C RETAINING RING
35	GSA06.35	BALANCING SHAFT
36	GSA06.36	LOCATING SLEEVE
37	GSA06.37	MUFFLE CONNECTOR
38	GSA06.38	LOCATING PIN
39	GSA06.39	VACUUM ADAPTER
40	GSA06.40	WRENCH
41	GSA06.41	DUST COLLECTING HOOD
42	GSA06.42	6" PAD
43	GSA06.43	DUST COLLECTING HOSE
44	GSA06.44	DUST COLLECTING BAG

NOTE: It is our policy to continually improve products and as such we reserve the right to alter data, specifications and component parts without prior notice.

IMPORTANT: No liability is accepted for incorrect use of product.

WARRANTY: Guarantee is 12 months from purchase date, proof of which will be required for any claim.