

Parts Information:
**700kg Capacity EV Battery Lift/Hydraulic
 Platform Truck High Lift
 Model No: EVBT700.V2**

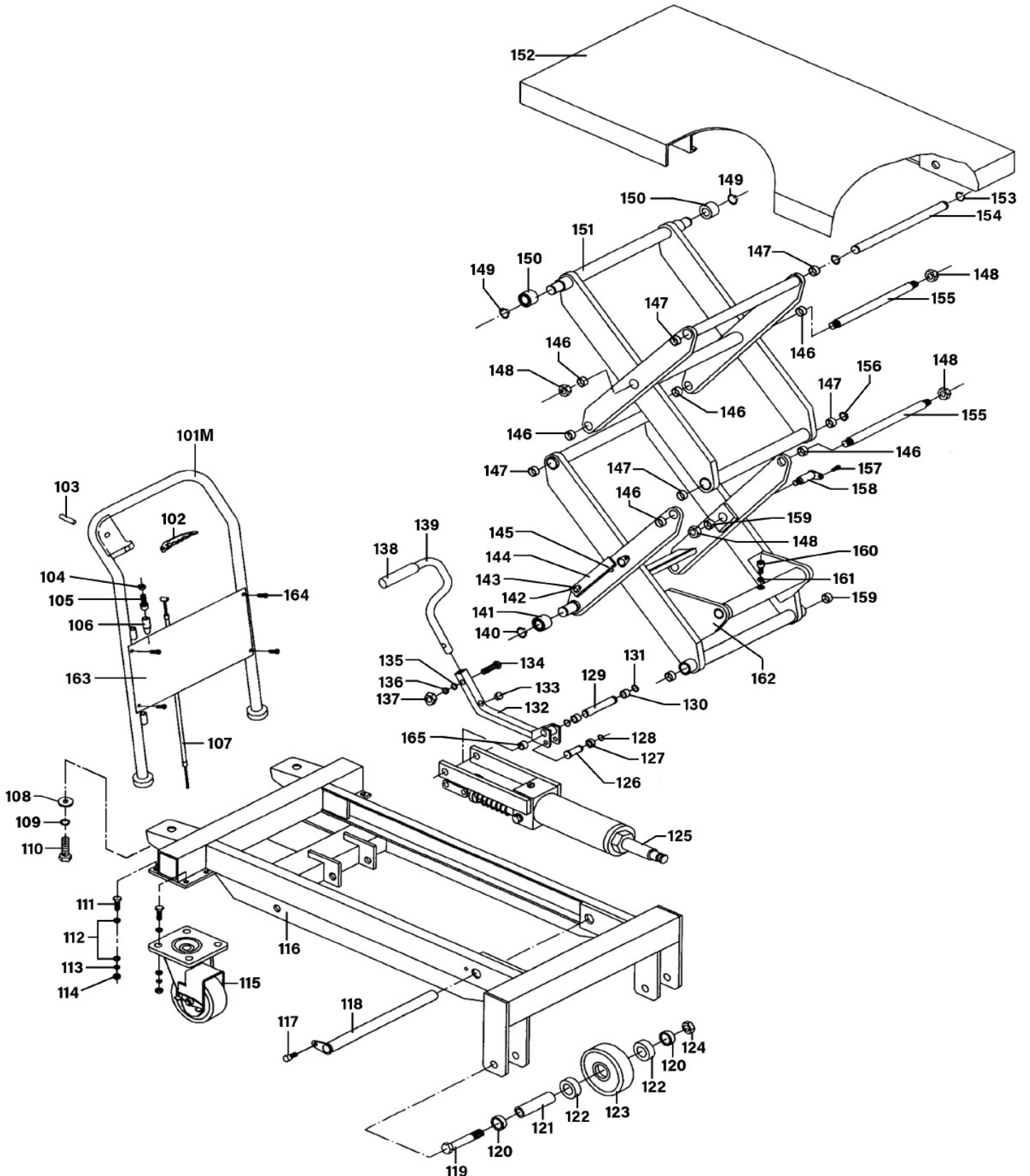

NOTE: It is our policy to continually improve products and as such we reserve the right to alter data, specifications and component parts without prior notice. There may be alternative versions of this product, please contact us should you require this information.

IMPORTANT: No liability is accepted for incorrect use of product. Spare parts must be fitted by a competent person

WARRANTY: Guarantee is 12 months from purchase date, proof of which will be required for any claim.



Parts Information:
**700kg Capacity EV Battery Lift/Hydraulic
 Platform Truck High Lift
 Model No: EVBT700.V2**

Item	Part No.	Description	Qty
101M	EVBT700-101M	Main Handle	1
102	EVBT700-102	Control Handle	1
103	EVBT700-103	Spring Pin (Ø6 x 30)	1
104	SN8.S	Steel Nut M8 Zinc	1
105	SCB835.S	Socket Cap Bolt M8 x 35mm	1
106	EVBT700-106	Protection Sleeve	1
107	EVBT700-107	Pull Rod	1
108	EVBT700-108	Washer (Ø13 x Ø45 x 6)	2
109	SWM12.S	Spring Washer M12 Zinc	2
110	SS1230.S	Hex Head Set Screw M12 X 30 Zinc	2
111	SS825.S	Hex Head Set Screw M8 X 25 Zinc	8
112	FWM8.S	Flat Washer M8 Zinc	16
113	SWM8.S	Spring Washer M8 Zinc	8
114	SN8.S	Steel Nut M8 Zinc	1
115	EVBT700-115	Wheel, Swivel Castor, 4-Bolt (w/ Brake)(D: 127 W: 40 B: 16 H: 168)	2
116	EVBT700-116	Main Frame	1
117	SS812.S	Hex Head Set Screw M8 X 12 Zinc	1
118	EVBT700-118	Shaft	1
119	HHB1275.S	Hex Head Bolt M12 x 75mm	2
120	EVBT700-120	Front Wheel Bush (Ø17 x Ø22 x 4)	4
121	EVBT700-121	Front Wheel Axle (Ø17 x Ø12 x 48)	2
122	B/6203-2RS	Bearing 6203-2rs	4
123	EVBT700-123	Wheel, Front Fixed (c/w Bearing) (D: 127 W: 40 B: 16)	2
124	SN12.S	Steel Nut M12 Zinc	2
125	EVBT700-125	Pump Unit Assembly	1
126	EVBT700-126	Pin (Ø10 x 31.5)	1
127	EVBT700-127	Roller (Ø10 x 31.5)	1
128	EVBT700-128	External Circlip Ø10	1
129	EVBT700-129	Pin (Ø10 x 42.5)	1
130	EVBT700-130	Bush	2
131	EVBT700-131	External Circlip	2
132	EVBT700-132	Connection Rod	1
133	EVBT700-133	Rubber Bung	1

Item	Part No.	Description	Qty
134	SS830.S	Hex Head Set Screw M8 X 30 Zinc	1
135	FWM8.S	Flat Washer M8 Zinc	16
136	SWM8.S	Spring Washer M8 Zinc	8
137	SN8.S	Steel Nut M8 Zinc	1
138	EVBT700-138	Pedal Bar Grip	1
139	EVBT700-139	Pedal Bar	1
140	EVBT700-140	External Circlip Ø30	2
141	EVBT700-141	Roller Ø63	2
142	SS816.S	Hex Head Set Screw M8 X 16 Zinc	2
143	EVBT700-143	Screw	2
144	EVBT700-144	Support Plate (6 x 30 x 325)	2
145	EVBT700-145	Nut	2
146	EVBT700-146	Bush	6
147	EVBT700-147	Bush	6
148	EVBT700-148	Nut (M24 x 1.5)	8
149	EVBT700-149	External Circlip Ø25	2
150	EVBT700-150	Roller Ø44	2
151	EVBT700-151	Fork Arm (A)	1
152	EVBT700-152	Table (Platform)	1
153	EVBT700-153	External Circlip	2
154	EVBT700-154	Fork Arm Shaft 'A'	1
155	EVBT700-155	Fork Arm Shaft 'B'	3
156	EVBT700-156	External Circlip	4
157	MSP816.S	Machine Screw Pan Head Phillips M8 x 16mm	2
158	EVBT700-158	Pivot Pin	2
159	EVBT700-159	Bush (Ø32 x Ø50 x 12)	4
160	EVBT700-160	Hex Socket Bolt	1
161	EVBT700-161	Washer	1
162	EVBT700-162	Fork Arm (B)	1
163	EVBT700-163	Back Panel	1
164	EVBT700-164	Screw for Back Panel	1
165	EVBT700-165	Roller	4

NOTE: It is our policy to continually improve products and as such we reserve the right to alter data, specifications and component parts without prior notice. There may be alternative versions of this product, please contact us should you require this information.

IMPORTANT: No liability is accepted for incorrect use of product. Spare parts must be fitted by a competent person

WARRANTY: Guarantee is 12 months from purchase date, proof of which will be required for any claim.

Sealey Group, Kempson Way, Suffolk Business Park, Bury St Edmunds, Suffolk. IP32 7AR



01284 757500



sales@sealey.co.uk



www.sealey.co.uk



Parts Information:
**700kg Capacity EV Battery Lift/Hydraulic
 Platform Truck High Lift
 Model No: EVBT700.V2**

Item	Part No.	Description	Qty
201	EVBT700-201	Seal Washer (Ø28 x Ø20 x 2)	1
202	EVBT700-202	Pump Cylinder	1
203	EVBT700-203	Dust Ring/Seal (Ø16 x Ø24 x 4.5)	1
204	EVBT700-204	Seal (Ø16 x Ø24 x 5)	1
205	EVBT700-205	Pump Piston (Ø16 x 144)	1
206	EVBT700-206	Pump Piston Spring (Ø45 x Ø5 x 164)	1
207	EVBT700-207	Spring Cap	1
208	EVBT700-208	External Circlip Ø10	1
209	EVBT700-209	Joint Plate	2
210	EVBT700-210	Pin (Ø10 x 31.5)	1
211	EVBT700-211	Pump Body	1
212	EVBT700-212	Spring Pin (Ø8 x 32)	1
213	EVBT700-213	Spring (Ø10.5 x Ø1.5 x 25.6)	1
214	EVBT700-214	Strike Pin	1
215	EVBT700-215	O-Ring	1
216	EVBT700-216	Axle Sleeve	1
217	EVBT700-217	O-Ring	2
218	SN8.S	Steel Nut M8 Zinc	1
219	EVBT700-219	Stud Screw M8 x 20	1
220	EVBT700-220	Lever Plate	1
221	SN8.S	Steel Nut M8 Zinc	1
222	SWM8.S	Spring Washer M8 Zinc	1
223	FWM8.S	Flat Washer M8 Zinc	1
224	EVBT700-224	Screw (w/Hole) M8 x 20	1
225	EVBT700-225	Screw (w/Hole) M8 x 22	1
226	SN8.S	Steel Nut M8 Zinc	1
227	EVBT700-227	Plug	1
228	EVBT700-228	O-Ring (Ø18 x 2.4)	1
229	EVBT700-229	Adjusting Bolt M14 x 1.5	1
230	EVBT700-230	Spring (Ø3 x Ø10 x 26)	1
231	EVBT700-231	Safety Valve Spindle	1

Item	Part No.	Description	Qty
232	SB-7.0	Steel Ball 7.0mm	1
233	EVBT700-233	O-Ring	1
234	EVBT700-234	Pump Valve Seat	1
235	EVBT700-235	Spring Base Seat	1
236	EVBT700-236	Spring (Ø6.7 x Ø0.5 x 14.5)	1
237	EVBT700-237	O-Ring	1
238	EVBT700-238	O-Ring	1
239	EVBT700-239	Seal Washer (Ø62 x Ø54 x 2)	1
240	EVBT700-240	Cylinder (Ø65 x Ø55 x 276)	1
241	EVBT700-241	Housing (Ø89 x 4 x 279)	1
242	EVBT700-242	Bolt for Housing M8 x 10	1
243	EVBT700-243	Seal Washer (Ø7.5 x Ø11.5 x 3)	1
244	EVBT700-244	External Circlip Ø24	1
245	EVBT700-245	Seal Washer (Ø53 x Ø24 x 4.8)	1
246	EVBT700-246	U-Ring Seal (Ø55 x Ø45 x 6)	1
248	EVBT700-248	Piston (Ø55 x 40)	1
249	EVBT700-249	O-Ring (Ø55 x 3.5)	1
250	EVBT700-250	Piston Rod (Ø40 x 318)	1
251	EVBT700-251	Seal Washer (Ø80 x 3.1)	1
252	EVBT700-252	Cylinder Cap M54 x 1.5	1
253	EVBT700-253	O-Ring (Ø46 x 3.5)	1
254	EVBT700-254	Dust Ring (Ø40 x Ø48 x 5)	1
255	EVBT700-255	Plug	1
256	EVBT700-256	Spring Clip	1
257	EVBT700-257	Set Screw	1
258	EVBT700-258	O-Ring	2
259	SCB1055.SB	Socket Cap Bolt M10 X 55mm Black	1
260	EVBT700-260	Cylinder Base Cap (Ø54 x 60)	1
261	EVBT700-261	External Circlip	1
--	EVBT700-RK	Repair Kit for Hydraulic Ram (not shown)	1

NOTE: It is our policy to continually improve products and as such we reserve the right to alter data, specifications and component parts without prior notice. There may be alternative versions of this product, please contact us should you require this information.

IMPORTANT: No liability is accepted for incorrect use of product. Spare parts must be fitted by a competent person

WARRANTY: Guarantee is 12 months from purchase date, proof of which will be required for any claim.

Sealey Group, Kempson Way, Suffolk Business Park, Bury St Edmunds, Suffolk. IP32 7AR



01284 757500



sales@sealey.co.uk



www.sealey.co.uk