

EDA150, ELECTRIC SANDER PARTS LIST & DIAGRAM

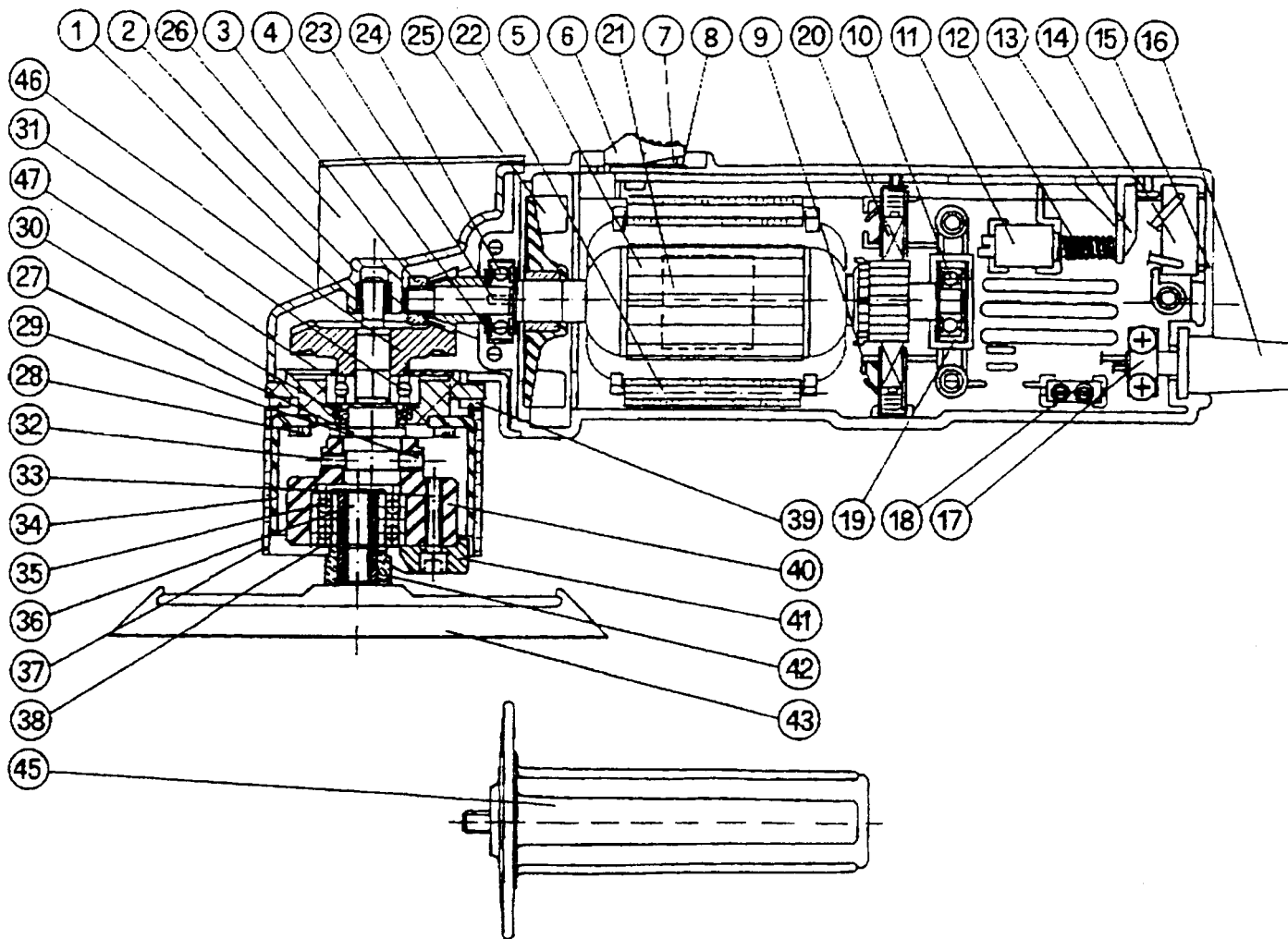

Index no.	Stock Code	Description	Qty
1	122/20.01.70	Bush	1
2	122/10.04.50	Body Box Gear	1
3	122/29.01.30	Nut	1
4	122/19.50.80	Distancer	1
5	122/17.31.50	Gasket	1
6	122/34.06.90	Switch Key	1
7	122/25.03.50	Switch Spring	1
8	122/34.06.91	Switch Plate	1
9	122/35.07.50	Brush Holder	2
10	B/607Z	Ball Bearing	1
11	122/34.06.92	Switch	1
12	122/25.03.55	Return Spring	1
13	122/27.01.30	Switch Lever	1
14	122/34.03.20	Condenser	1
15	122/10.04.55	Plastic Body	1
16	122/34.04.05	Cable Guard	1
17	122/34.04.10	Cable Holder	1
18	122/34.05.05	Terminal Board	1
19	122/34.08.05	Rubber Cover	1
20	122/34.07.58	Brush	2
21	122/50.01.50	Rotor	1
22	122/35.02.50	Stator	1
23	122/24.01.35	Rubber	1
24	B/608Z	Ball Bearing	1

Index no.	Stock Code	Description	Qty
25	122/50.01.54	Fan	1
26	122/22.50.20	Iron Protection	1
27	122/18.03.30	Shaft	1
28	122/11.06.18	Screw	2
29	122/11.05.01	Screw	2
30	122/19.48.05	Dust Guard	1
31	B/6000	Ball Bearing	1
32	122/11.05.10	Screw	1
33	122/11.06.05	Screw	1
34	122/22.07.10	Protection	1
35	B/6001-2RS	Ball Bearing	2
36	122/32.01.13	Eccentric Shaft	1
37	122/24.04.40	Rubber Protection	1
38	122/19.50.02	Dust Guard	1
39	122/11.07.01	Screw	4
40	122/32.03.13	Eccentric Body	1
41	122/14.06.15	Counterbalance	1
42	122/32.01.24	Hexagonal Eccentric Shaft	1
43	PTC/150A	Sanding Pad	1
	PTC/150SA	Sanding Pad	
45	122/10.03.50	Side Handle	1
46	122/16.50.10	Gear	1
47	122/19.48.10	Bearing Cover	1
	122/32.03.12	Eccentric Group Kit	



JACK SEALEY LTD
KEMPSON WAY
SUFFOLK BUSINESS PARK
BURY ST EDMUNDS
SUFFOLK IP32 7AR
TEL: 01284 757500 FAX: 01284 703534

Original Date:	11/7/95
Issue Date:	11/7/95
Version Number:	1
Date Modified:	