

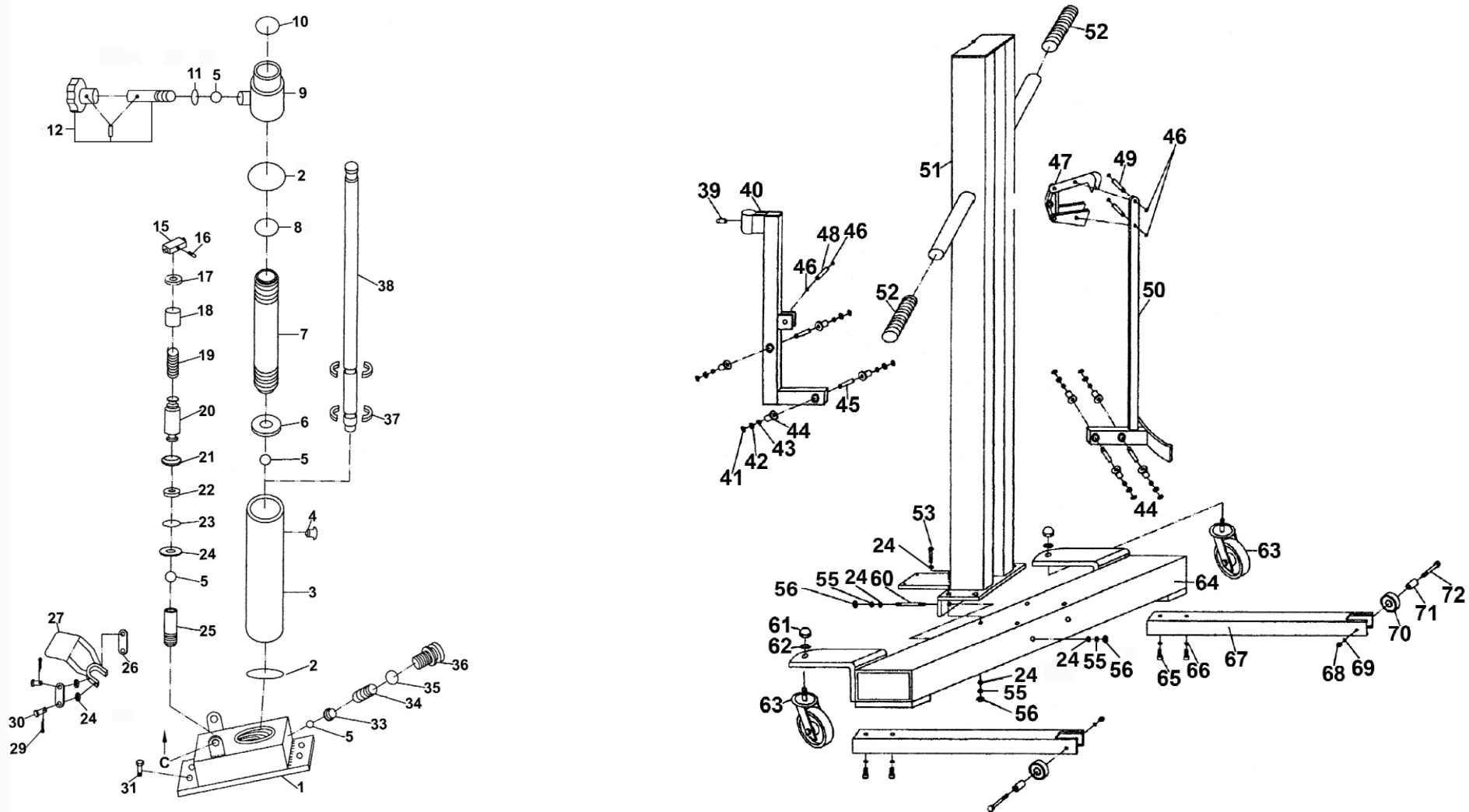

Parts Information: Hydraulic Drum Truck & Van Loader 205ltr Model No: DH03



NOTE: It is our policy to continually improve products and as such we reserve the right to alter data, specifications and component parts without prior notice.

There may be alternative versions of this product, please contact us should you require this information.

IMPORTANT: No liability is accepted for incorrect use of product. Spare parts must be fitted by a competent person

WARRANTY: Guarantee is 12 months from purchase date, proof of which will be required for any claim.

Sealey Group, Kempson Way, Suffolk Business Park, Bury St Edmunds, Suffolk. IP32 7AR

01284 757500 | 01284 703534 | sales@sealey.co.uk | www.sealey.co.uk



Parts Information: Hydraulic Drum Truck & Van Loader 205ltr Model No: DH03

Item	Part No.	Description
1	DH03.01	Base
2	DH03.02	O-ring, (Ex: 59.86 In: 54.62 Cs: 2.62)
3	DH03.03	Reservoir
4	DH03.04	Oil Plug
5	SB-6.4	Steel Ball 6.4mm
6	DH03.06	Seal
7	DH03.07	Cylinder
8	AK45X.V2-29	O-Ring, (Ex: 41.58 In: 34.52 Cs: 3.53)
9	DH03.09	Head
10	DH03.10	O-Ring, (Ex: 30.98 In: 24.90 Cs: 3.04)
11	DH03.V2-39	O-Ring, (Ex: 12.81 In: 9.25 Cs: 1.78)
12	DH03.V2-KIT	Grip With Rod & Pin
15	DH03.15	Block
16	GSM612.S	Set Screw
17	DH03.17	Plain Steel Washer
18	DH03.18	Dust Protector
19	DH03.19	Spring Dia 31.4mm
20	DH03.20	Piston
21	DH03.21	Dust Seal
22	DH03.22	Seal
23	DH03.23	O-Ring, (Ex: 23.07 In: 17.83 Cs: 2.62)
24	FWM12.S	Flat Washer M12 Zinc
25	DH03.25	Pump Housing
26	DH03.26	Link
27	DH03.27	Pedal
29	DH03.29	Cotter Pin 3.6 x 18
30	DH03.30	Pin
31	SCB820.SB	Socket Cap Bolt M8 x 20mm Black
33	DH03.33	Spring Guide
34	DH03.34	Spring Dia 7.6mm
35	WK025.V2-31	O-Ring, (Ex: 14.43 In: 9.19 Cs: 2.62)
36	DH03.36	Bolt
37	DH03.37	Half Ring

Item	Part No.	Description
38	DH03.38	Piston
39	GSM810.S	Grub Screw M8x10
40	DH03.40	Lifting Arm
41	RE231.V3-06	External Circlip 13.6mm ID
42	DH03.42	Seal Ring Washer Thin
43	DH03.43	Bushing
44	DH03.44	Roller
45	DH03.45	Pin
46	ER1700PD.37	External Circlip 11.6mm ID
47	DH03.47	Fulcrum Assy
48	DH03.48	Pin
49	DH03.49	Pin
50	DH03.50	Support Frame
51	DH03.51	Post
52	DH03.V2-52	Handle Grip
53	HHB11280.S	Hex Head Bolt M12 x 80mm
55	SWM12.S	Spring Washer M12 Zinc
56	SN12.S	Steel Nut M12 Zinc
60	HHB12130.S	Hex Head Bolt M12 x 130mm
61	SN12.SD	Steel Nut M12 Domed Zinc
62	SWM12.SB	Spring Washer M12 Black
63	DH03.63	Swivel Castor 100x35x7
64	DH03.64	Base Frame
65	SCB1025.SB	Socket Cap Bolt M10 x 25mm Black
66	SWM10.SB	Spring Washer M10 Black
67	DH03.V2-71	Leg
68	SN8.S	Steel Nut M8 Zinc
69	SWM8.SB	Spring Washer M8 Black
70	DH03.70	Wheel, Fixed White Plastic (D:65 W:33 B:20)
71	DH03.71	Bushing
72	HHB860.S	Hex Head Bolt M8 x 60mm
--	DH03.73	Hydraulic Unit (Not Shown)
--	DH03.52-1	Handle (Not Shown)

NOTE: It is our policy to continually improve products and as such we reserve the right to alter data, specifications and component parts without prior notice. There may be alternative versions of this product, please contact us should you require this information.

IMPORTANT: No liability is accepted for incorrect use of product. Spare parts must be fitted by a competent person

WARRANTY: Guarantee is 12 months from purchase date, proof of which will be required for any claim.

Sealey Group, Kempson Way, Suffolk Business Park, Bury St Edmunds, Suffolk. IP32 7AR



01284 757500



01284 703534



sales@sealey.co.uk



www.sealey.co.uk