

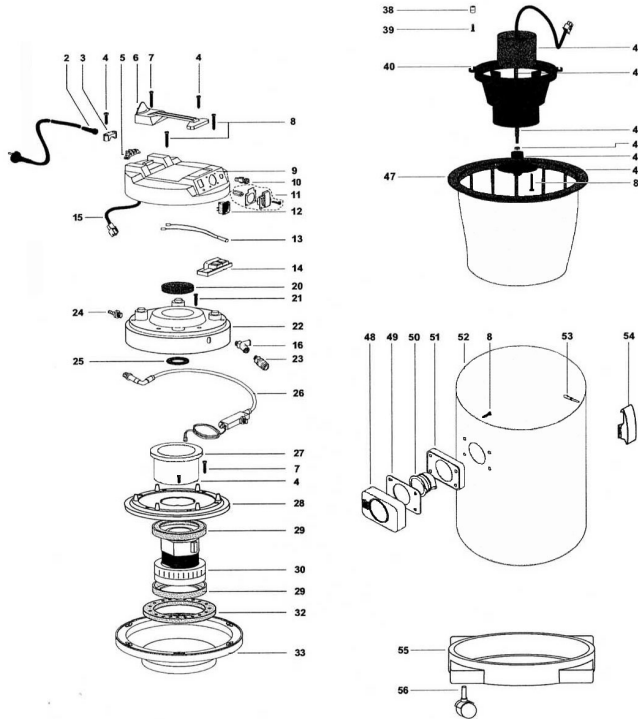

Parts Information:  
**Dust-Free Vacuum System with MAT150AS**  
**Air/Electric**  
**Model No: DFS91A.V4**



Item	Part No.	Description
2	122.00138	CABLE SLEEVE
3	122.00139	CABLE GRIP
4	122.01006	SCREW (5x20)
5	122.03443	CLAMP
6	122.03733RN	RED HANDLE
7	122.02627	SCREW (5x40)
8	122.01026	SCREW (5x30)
9	122.03734G6	TOP COVER
10	122.34.06.78	TRIGGER, FILTER SHAKER
11	122.34.02.021	SOCKET KIT
12	122/34.03.75	SWITCH MANUAL/AUTOMATIC
13	122/74.01.17	LED INDICATOR
14	122.98.04.10	ELECTRONIC CARD, FILTER SHAKER
15	122.020284	WIRE, FILTER SHAKER
16	122/97.43.22	CONNECTION 3/8" M,F,F
20	122.03937	FILTER
21	122.01050	SCREW (5x35)
22	122.02738RN	RED MOTOR COVER, UPPER
23	122/97.08.03U	TAP 3/8" UNIVERSAL
24	122.97.32.39	AIR INLET
25	122.03969	GASKET
26	122.99.03.301	ELECTRO-PNEUMATIC VALVE KIT (W SERIES)
27	122.03900	FILTER
28	122.R2634G6	MOTOR COVER, MIDDLE

Item	Part No.	Description
29	122.03901	GASKET
30	122.03891CL1	MOTOR (GROUNDED)
32	122.03866	SILENCER
33	122.R2636G6	MOTOR COVER, LOWER
38	122.03706	DISTANCER
39	122.03724	SCREW (5x25)
40	122.02822	BODY, FILTER SHAKER
41	122.07715	ELECTROMAGNET 230V, FILTER SHAKER
42	122.07825	STEEL ROD, ELECTROMAGNET
43	122.07671	ROD, FILTER SHAKER
44	SN8.S	STEEL NUT M8 ZINC DIN934 (SINGLE)
45	122.06363	TENSER FOOT
46	122.07675	PROTECTION COVER, FILTER SHAKER
47	122.03241	FILTER BAG (O.D. 335mm)
48	122.02652AG6	HOSE INLET, RED BUTTON
49	122.02846	GASKET, HOSE INLET
50	122.02593	DEFLECTOR
51	122.02586G6	GASKET
52	122.R6132	TANK
53	122.01302	RIVET
54	122.01847	CLIP, BIN
55	122.01218G6	BASE, TROLLEY
56	122.00558	WHEEL,CASTOR (D:41xW:30xH:50)

**NOTE:** It is our policy to continually improve products and as such we reserve the right to alter data, specifications and component parts without prior notice.

**IMPORTANT:** No liability is accepted for incorrect use of product.

**WARRANTY:** Guarantee is 12 months from purchase date, proof of which will be required for any claim.

**Sealey Group**, Kempson Way, Suffolk Business Park, Bury St Edmunds, Suffolk. IP32 7AR



01284 757500



01284 703534



sales@sealey.co.uk



www.sealey.co.uk



Parts Information:  
**Dust-Free Vacuum System with MAT150AS**  
**Air/Electric**  
**Model No: DFS91A.V4**

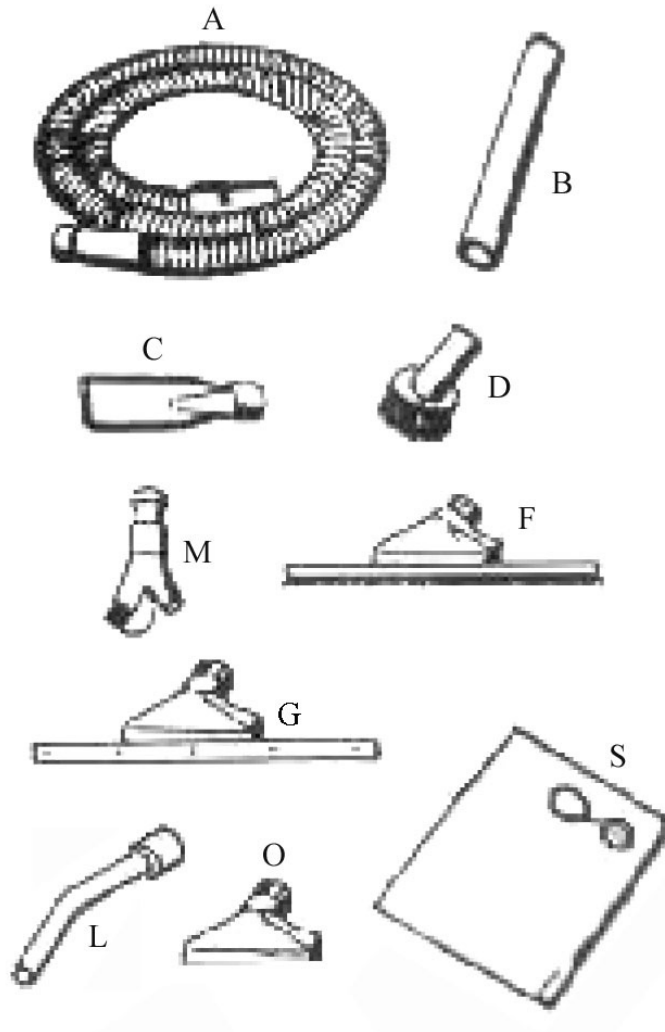

Item	Part No.	Description
A	122.01685	FLEXIBLE HOSE (36mm x 2.50m)
B	122.06526	HOSE RIGID EXT.
C	122.00617	FLAT NOZZLE
D	122.00004	90deg BRUSH
F	122.R3367	FLOOR BRUSH
G	122.R3967	LIQUIDS ADAPTOR(INCLUDES BLACK COVER)

Item	Part No.	Description
L	122.06158	EXTENSION
M	122.36.01.45	DOUBLE CONNECTION
O	122.00616	UPHOLSTERY NOZZLE
S	122.99.70.301	DISPOSABLE TIE UP DUST BAG FS91A/B Pack
--	120.021471	DIODE BOARD PCB FOR SHAKER (NOT SHOWN)

**NOTE:** It is our policy to continually improve products and as such we reserve the right to alter data, specifications and component parts without prior notice.

**IMPORTANT:** No liability is accepted for incorrect use of product.

**WARRANTY:** Guarantee is 12 months from purchase date, proof of which will be required for any claim.

**Sealey Group**, Kempson Way, Suffolk Business Park, Bury St Edmunds, Suffolk. IP32 7AR



01284 757500



01284 703534



sales@sealey.co.uk



www.sealey.co.uk