

## 5. PARTS LIST

Original Date:- 010299  
 Issue Date:-  
 Version Nbr:- 0  
 Date Modified:- N/A

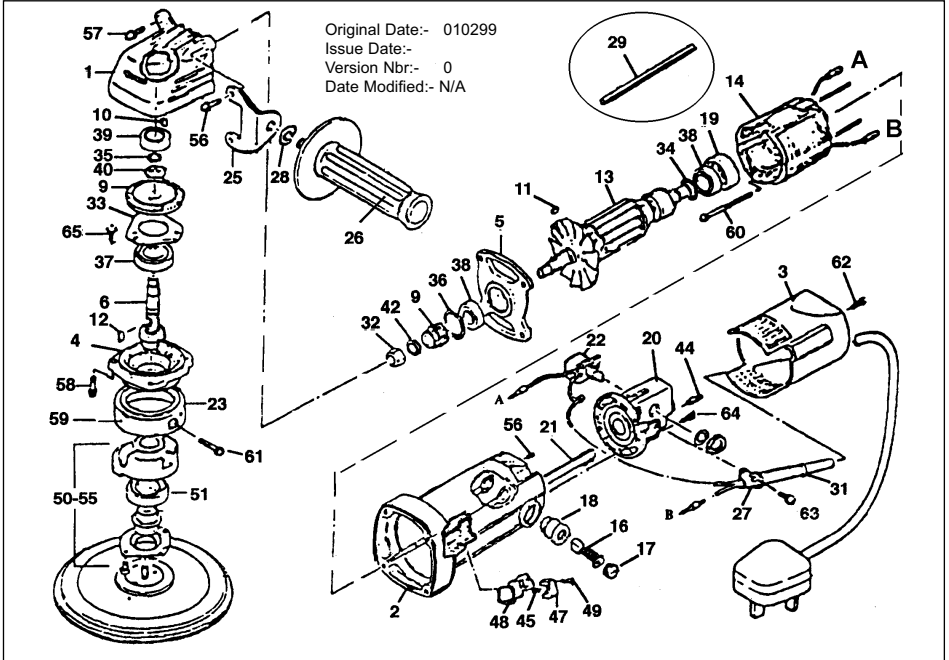

ITEM NO	PART NO	DESCRIPTION	ITEM NO	PART NO	DESCRIPTION	ITEM NO	PART NO	DESCRIPTION
1	102/153001	Head	23	102/153023	Balancer Ring	48	102/103048	Switch Button, Spring & Lock
2	102/103002	Body	25	102/107025	Grip Fitting Plate	49	102/103049	Screw, M5 x 8
3	102/103003	End Case	26	102/122026	Grip	50-55	102/153050	Balancer Set
4	102/153004	Head Cap	27	102/100027	Band	56	B/6202-RS	Bearing
5	102/105005	Centre Bracket	28	102/120050	Spring Washer, M10	57	102/100056	Screw, M4 x 6
6	102/153006	Gear Shaft	29	102/153029	Bar Wrench	58	102/100057	Screw, M5 x 20
9	102/153009	Gear Set	31	102/100031	Anti-kink Sleeve	58	102/153058	Screw, M4 x 14
10	102/100019	Rubber, Ø 4	32	102/100032	Lock Nut	59	102/100056	Screw, M4 x 6
11	102/100011	Woodruff Key, Ø 10mm	33	102/100033	Bearing Fitting Plate	60	102/100060	Screw, M4 x 60
12	102/100012	Woodruff Key, Ø 13mm	34	102/153034	Dust Plate	61	102/153061	Screw, M6 x 25
13	102/153013	Armature, 240 Volt	35	102/100035	Stop Ring, S-10	62	102/100062	Screw, M4 x 12
14	102/153014	Field Coil, 240 Volt	36	102/100036	Stop Ring, R-22	63	102/100062	Screw, M4 x 12
16	102/100016	Carbon Brush	37	B/6200-2RS	Bearing	64	102/100058	Screw, M4 x 16
17	102/100017	Brush Holder Cap	38	B/608-2RS	Bearing	65	102/100061	Screw, M4 x 10
18	102/100018	Brush Holder	39	B/B/608Z	Bearing	66	102/106057	Screw, M5 x 25
19	102/103019	Bearing Cap	40	102/105041	Wave Washer	102/DFS-BRACKET		DFS Dust Hose
20	102/103020	Switch Fitting Plate	42	102/100042	Spring Washer			Mounting Bracket
21	102/103021	Switch Lever	44	102/105044	Switch Spring			
22	102/153022	Switch, On/Off	46	102/100045	Connector Set			

### Declaration of Conformity

We, the sole importer into the UK, declare that the products listed here are in conformity with the following EEC standards and directives. The construction files for these products are held by the Manufacturer and may be inspected on request by contacting Jack Sealey Ltd

DUAL ACTION SANDER Models: DAS150 & DAS150/DFS  
 73/23/EEC Low Voltage Directive (S.I. 1994/3260).  
 89/336/EEC EMC Directive (S.I. 1992/2372) and amendments.  
 89/392/EEC Machinery Directive (S.I. 1992/3073) and amendments



Signed by Mark Sweetman  
 1st March 1999

For Jack Sealey Ltd. Sole importer into the UK of Sealey Power Tools

**NOTE:** It is our policy to continually improve products and as such we reserve the right to alter data, specifications and component parts without prior notice. **IMPORTANT:** No liability is accepted for incorrect use of this equipment. **WARRANTY:** Guarantee is 12 months from purchase date, proof of which will be required for any claim. **INFORMATION:** Call us for a copy of our latest catalogue on 01284 757525 and leave your full name and address including your postcode.



Sole UK Distributor, Sealey Group, Bury St. Edmunds, Suffolk.



01284 757500



01284 703534

E-mail: sales@sealey.co.uk