

Parts Information:
Bench Grinder 150mm with Wire Wheel
450W/230V Heavy-Duty
Model No: BG150XW/99

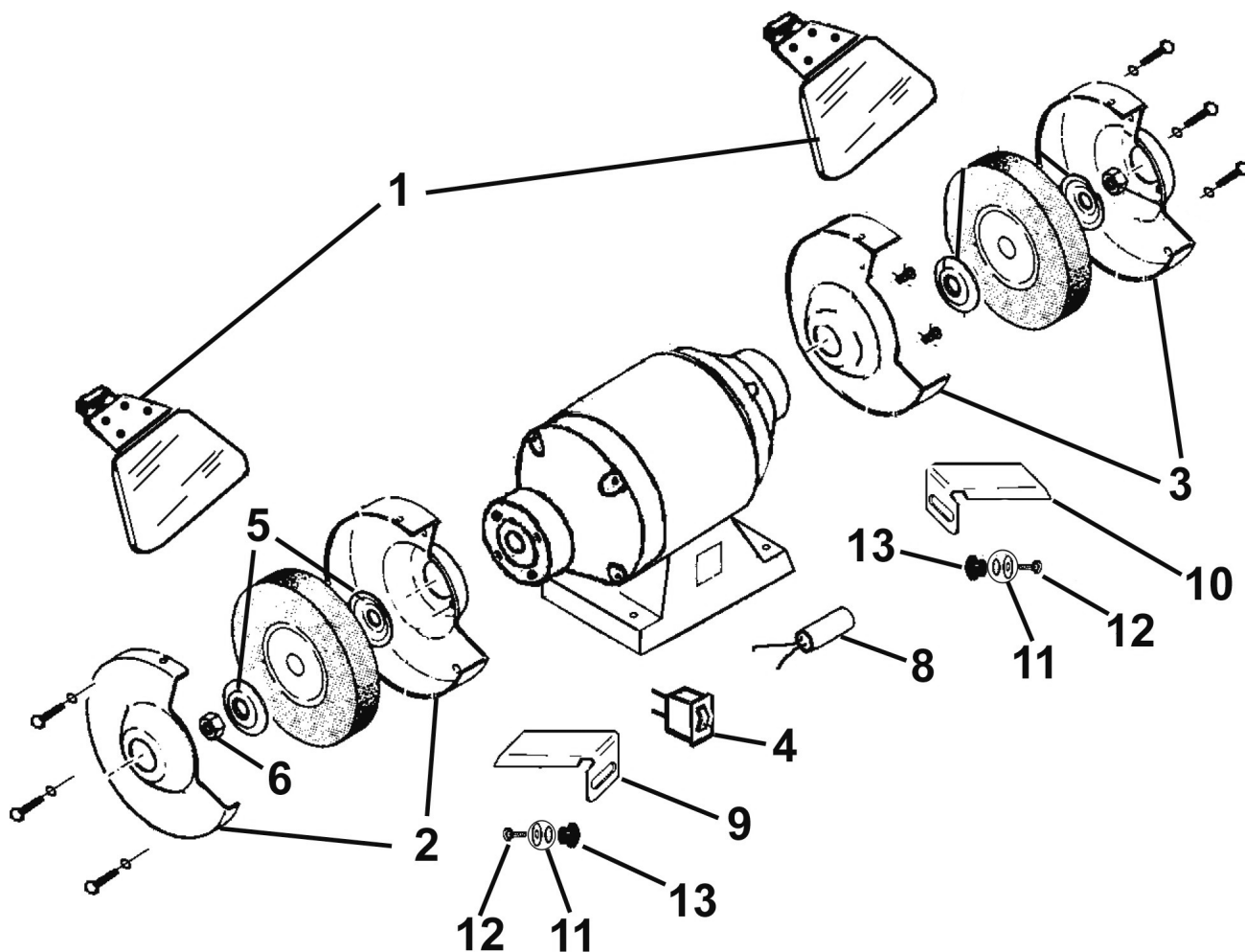

Item	Part No.	Description
1	BG150XD99-01A	Eyeshield Bracket Assembly
2	BG150XD/99-02	Wheel Guard, Left (c/w Fixings)
3	BG150XD/99-03	Wheel Guard, Right (c/w Fixings)
4	BG150XD/99-04	Power, Switch, Rocker (c/w Plate)
5	BG150XD/99-05	Washer
6	SN12.S	Steel Nut M12
8	BG150XD/99-08	Capacitor

Item	Part No.	Description
9	BG150XL/96-08	Tool Rest, Left
10	BG150XD/99-10	Tool Rest, Right
11	RW619.S	Repair Washer M6 X 19mm
12	CBN612.S	Coach Bolt M6 x 12mm
13	BG150CX.V3-29	Work Handle
--	BG150XD/99-01	Eyeshield (Not Shown)

NOTE: It is our policy to continually improve products and as such we reserve the right to alter data, specifications and component parts without prior notice. There may be alternative versions of this product, please contact us should you require this information.

IMPORTANT: No liability is accepted for incorrect use of product. Spare parts must be fitted by a competent person

WARRANTY: Guarantee is 12 months from purchase date, proof of which will be required for any claim.