

NOTE: It is our policy to continually improve products and as such we reserve the right to alter data, specifications and component parts without prior notice. There may be alternative versions of this product, please contact us should you require this information.

IMPORTANT: No liability is accepted for incorrect use of product. Spare parts must be fitted by a competent person

WARRANTY: Guarantee is 12 months from purchase date, proof of which will be required for any claim.



Parts Information:
Oil Dispensing System Air Operated
Model No: AK4561D.V2

Item	Part No.	Description
1	AK4560D.01	Air motor Cover
2	AK4560D.02	Piston
3	AK4560D.03	Air Motor Shell Inner
4	AK4560D.04	Air Motor Shell Outer
5	AK4560D.05	Bracket
6	AK4560D.06	Air Control Centre
7	AK4560D.07	Slider
8	AK4560D.08	Gasket
9	AK4560D.09	Soft Gasket
10	AK4560D.10	Square Hole Securing Washer
11	AK4560D.11	Bracket
12	AK4560D.12	Washer
13	AK4560D.13	Connect Tube
14	AK4560D.14	Suction Tube 850mm x 42mm od
15	AK4560D.15	Spring Circlip
16	AK4560D.16	Valve Seat
17	AK4560D.17	Filter or Connector
18	AK4560D.18	Piston
19	AK4560D.19	Connecting Shell
20	AK4560D.20	Connect Shaft
21	AK4560D.21	Connect Shell
22	AK4560D.22	Middle Shaft
23	AK4560D.23	Air Centre Cover
24	AK4560D.24	Slider Shell
25	AK4560D.25	Piston Shaft
26	FWM10.S	Flat Washer M10 Zinc
27	AK4560D.27	Spring Shell

Item	Part No.	Description
28	AK4560D.28	Spring
29	AK4560D.29	Spring Seat
30	AK4560D.30	Trip Shoe Guide
31	AK4560D.31	Press Piece
32	AK4560D.32	Nut
33	AK4560D.33	Outlet
98	AK4560D.98	Pin
99	SA51/08	Spring Pin M3 X 20
100	SB-21.4	Steel ball 21.4mm
101	AK4560D.101	Internal Circlip 17.4mm
102	SB-16.0	Steel Ball 16.0mm
103	MSP410.S	Machine Screw Pan Head Phillips M4 X 10mm
204	AK4560D.209	O-Ring, (Ex: 71.58 In: 66.34 Cs: 2.62)
205	AK453X.V3-P03	O-Ring, (Ex: 66.84 In: 61.60 Cs: 2.62)
206	SA342.12	O-Ring, (Ex: 14.38 In: 10.82 Cs: 1.78)
207	AK4560D.207	Silencer
208	SA686.36	O-Ring, (Ex: 22.33 In: 18.77 Cs: 1.78)
209	AK4560D.209	O-Ring, (Ex: 71.58 In: 66.34 Cs: 2.62)
210	AK453X.V3-P49	O-Ring, (Ex: 46.18 In: 40.94 Cs: 2.62)
211	MT700.V2-R10	O-Ring, (Ex: 25.53 In: 20.29 Cs: 2.62)
212	SA141.24	O-Ring, (Ex: 28.68 In: 25.12 Cs: 1.78)
213	AK4560D.213	O-Ring, (Ex: 41.41 In: 36.17 Cs: 2.62)
214	AK4560D.214	Seal
215	AK4560D.215	Guiding
216	AK4560D.216	Quick Coupling
217	AK4560D.217	Od Seal

NOTE: It is our policy to continually improve products and as such we reserve the right to alter data, specifications and component parts without prior notice. There may be alternative versions of this product, please contact us should you require this information.

IMPORTANT: No liability is accepted for incorrect use of product. Spare parts must be fitted by a competent person

WARRANTY: Guarantee is 12 months from purchase date, proof of which will be required for any claim.

Sealey Group, Kempson Way, Suffolk Business Park, Bury St Edmunds, Suffolk. IP32 7AR



01284 757500



01284 703534



sales@sealey.co.uk



www.sealey.co.uk

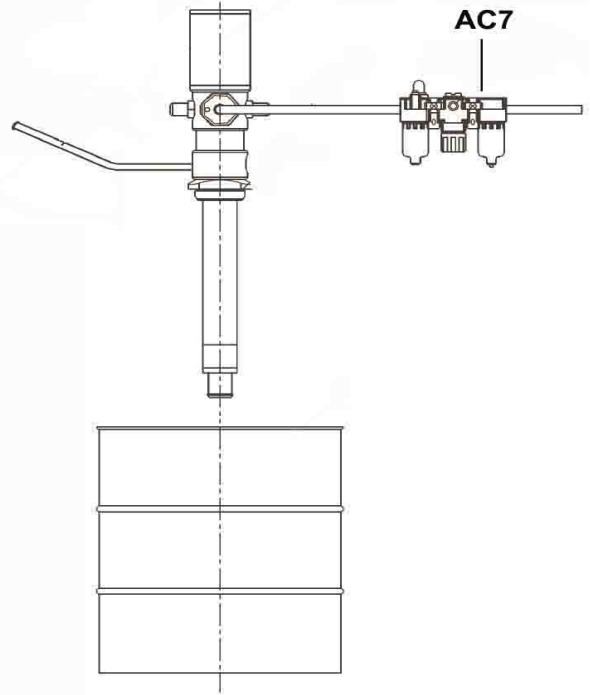
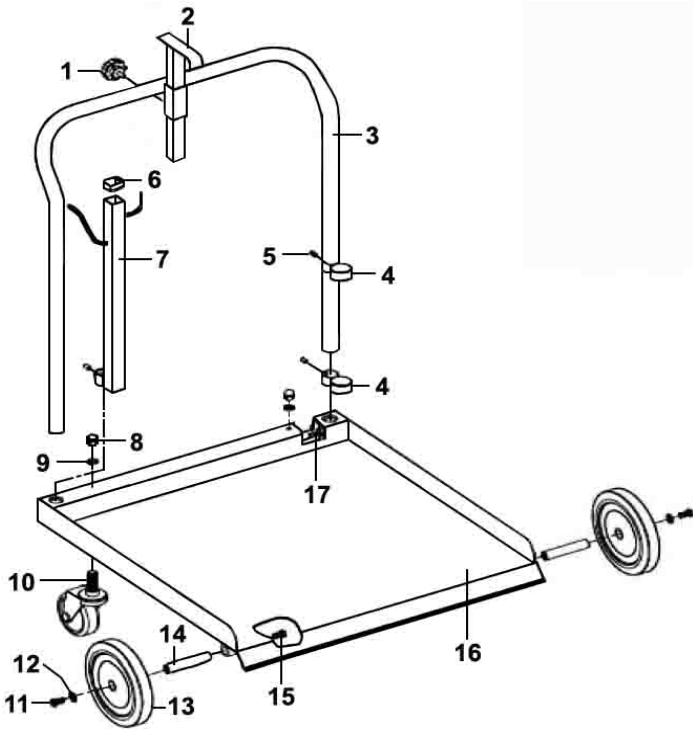

Item	Part No.	Description
1	AK4561D.01	Adjusting Knob
2	AK4562D.02	Drum holder support
3	AK4561D.03	Handle
4	AK4562D.04	Pump Support
5	GSM1010.S	Grub Screw M10 X 10
6	AK4562D.06	End Cap
7	AK4562D.07	Accessories Support
8	SN10.SD	Steel Nut M10 Domed
9	FWM10.S	Flat Washer M10 Zinc
10	AK4561D.10N	Wheel, Swivel Castor, Single Bolt (D:75 W:25 B:8 H:150)

Item	Part No.	Description
11	SFS816.S	Hex Head Flange Bolt M8 X 16 Zinc
12	RW838.S	Repair Washer M8 X 38 Zinc
13	AK4561D.13N	Wheel, Fixed Nylon (D:150 W:37 B:15)
14	AK4561D.14	Axle
15	SS645.S	Hex Head Set Screw M6 X 45 Zinc
16	AK4561D.16N	Trolley Base (New Type) (Not Shown)
17	GSM1010.S	Grub Screw M10 X 10
AC7	AK4560D.AC7	Regulator/lubricator/filter
--	AK4565D	Oil Hose End Gun with Digital Meter (Not Shown)

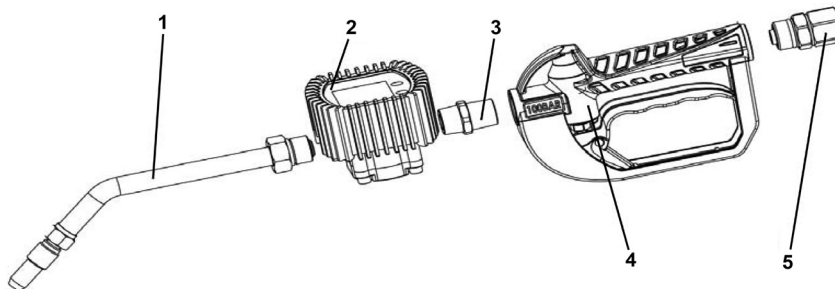

Item	Part No.	Description
1	AK4565D.V2-01	Flexible Nozzle
2	AK4565D.V2-02	Digital Meter
3	AK4565D.V2-03	Union Adaptor

Item	Part No.	Description
4	AK4565D.V2-04	Gun Handle
5	AK4565D.V2-05	Swivel Fitting 1/2"

NOTE: It is our policy to continually improve products and as such we reserve the right to alter data, specifications and component parts without prior notice. There may be alternative versions of this product, please contact us should you require this information.

IMPORTANT: No liability is accepted for incorrect use of product. Spare parts must be fitted by a competent person

WARRANTY: Guarantee is 12 months from purchase date, proof of which will be required for any claim.