

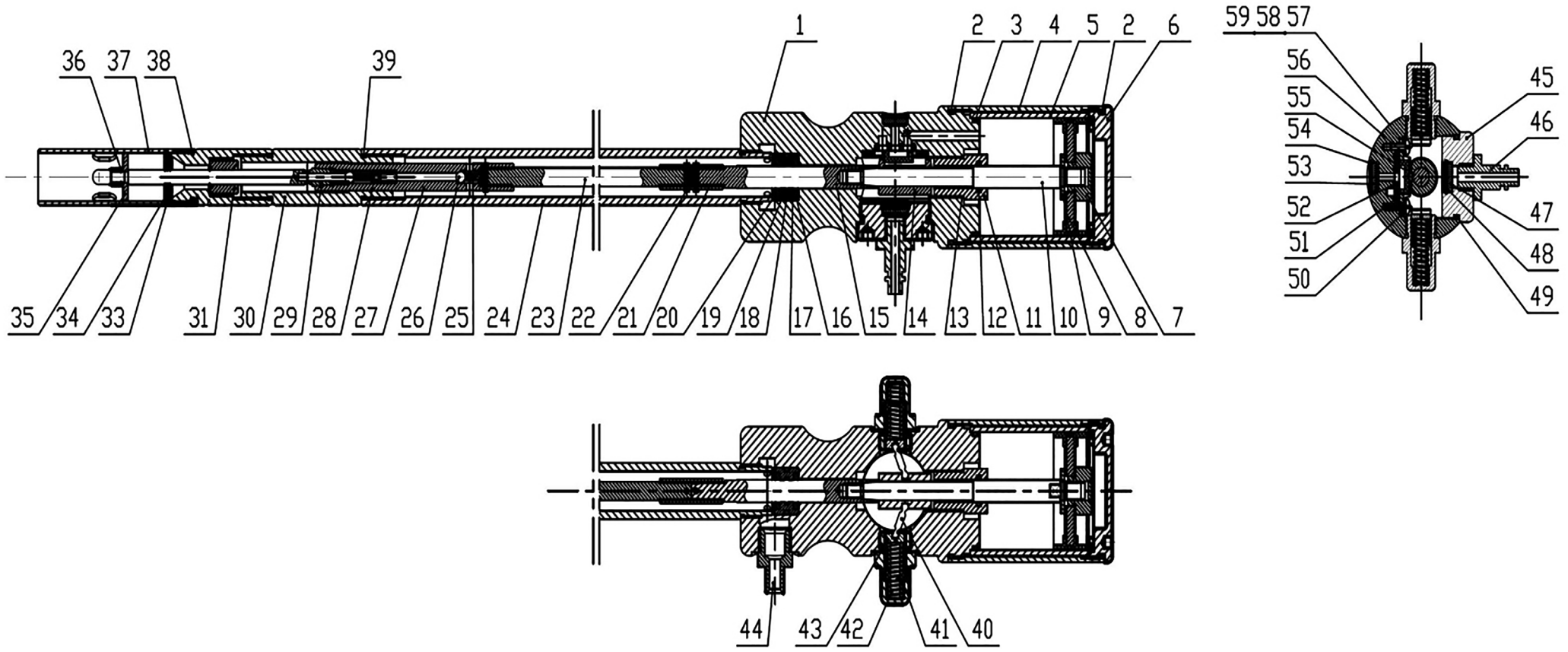

Parts Information:  
**Grease Pump Air Operated 50kg**  
**Model No: AK453X.V3**

## PUMP ASSEMBLY



**NOTE:** It is our policy to continually improve products and as such we reserve the right to alter data, specifications and component parts without prior notice.

There may be alternative versions of this product, please contact us should you require this information.

**IMPORTANT:** No liability is accepted for incorrect use of product. Spare parts must be fitted by a competent person

**WARRANTY:** Guarantee is 12 months from purchase date, proof of which will be required for any claim.

**Sealey Group**, Kempson Way, Suffolk Business Park, Bury St Edmunds, Suffolk. IP32 7AR

01284 757500 | sales@sealey.co.uk | www.sealey.co.uk



Parts Information:  
Grease Pump Air Operated 50kg  
Model No: AK453X.V3

Item	Part No.	Description
1	AK453X.V3-P01	Cylinder Block
2	AK453X.V3-P02	O-Ring (73.19 x 67.95 x 2.62)
3	AK453X.V3-P03	O-Ring (66.84 x 61.60 x 2.62)
4	AK453X.V3-P04	Air Motor Shell, External
5	AK453X.V3-P05	Air Motor Shell, Internal
6	AK453X.V3-P06	Cover, Air Motor
7	AK453X.V3-P07	Nut
8	AK453X.V3-P08	Rubber Piston Block
9	AK453X.V3-P09	Gasket
10	AK453X.V3-P10	Piston Shaft
11	AK453X.V3-P11	Guide Sleeve, Piston Rod
12	SA695.13	O-Ring (16.01 x 10.77 x 2.62)
13	SA686.36	O-Ring (22.33 x 18.77 x 1.78)
14	AK453X.V3-P14	Sliding Sleeve
15	AK453X.V3-P15	Centre Shaft / Centre shaft
16	AK453X.V3-P16	Oil Seal, Green (ID: 12mm)
17	AK453X.V3-P17	Sealing Socket
18	MT700.V2-R10	O-Ring (25.53 x 20.29 x 2.62)
19	AK453X.V3-P19	O-Ring (15.63 x 11.77 x 1.93)
20	AK453X.V3-P20	Gasket
21	AK453X.V3-P21	Connect Shell
22	SA2/05	Spring Pin M3 x 14mm
23	<b>AK453X.V3-P23</b>	<b>Connect Shaft (New Type) 10 x 428mm</b>
23	<b>AK453X.V3-P23A</b>	<b>Connect Shaft (Old Type) 10 x 425mm</b>
24	AK453X.V3-P24	Outer Sleeve
25	AK453X.V3-P25	Compression Spring Ø 4mm
26	SB-6.0	Steel Ball 6.0mm
27	AK453X.V3-P27	Piston
28	AK453X.V3-P28	Spring Seat

Item	Part No.	Description
29	AK453X.V3-P29	Shaft
30	AK453X.V3-P30	Plug Sleeve
31	AK453X.V3-P31	Valve Set
33	AK453X.V3-P33	Filter Plate
34	AK453X.V3-P34	Internal Circlip (OD: 32.0mm)
35	AK453X.V3-P35	Extract Plate
36	NLN6.S	Nyloc Nut M6
37	AK453X.V3-P37	Tube
38	AK453X.V3-P38	O-Ring (27.08 x 23.52 x 1.78)
39	SA0615KIT.08	O-Ring (23.91 x 20.35 x 1.78)
40	AK453X.V3-P40	Toggle Block
41	AK453X.V3-P41	Outer Spring Fixed Seat
42	AK453X.V3-P42	Compression Spring Ø 9.8mm
43	AK453X.V3-P43	Inner Spring Fixed Seat
44	AK453X.V3-P44	Joint
45	AK453X.V3-P45	Seal Cover
46	AK453X.V3-P46	Nut, Air Chamber Cover (c/w Quick Coupling)
47	AK453X.V3-P47	Silencer
48	MC4500.P5	External Circlip (ID: 14.5mm)
49	AK453X.V3-P49	O-Ring (46.18 x 40.94 x 2.62)
50	AK453X.V3-P50	Limit Plate
51	AK453X.V3-P51	Gasket
52	AK453X.V3-P52	Gasket
53	AK453X.V3-P53	Silencer
54	600TR/27	External Circlip (ID: 14.5mm)
55	AK453X.V3-P55	Panel
56	AK453X.V3-P56	Plate
57	MSP410.S	Machine Screw Pan Head Phillips M4 x 10mm
58+59	SWM4.S	Spring Washer M4

**NOTE:** It is our policy to continually improve products and as such we reserve the right to alter data, specifications and component parts without prior notice. There may be alternative versions of this product, please contact us should you require this information.

**IMPORTANT:** No liability is accepted for incorrect use of product. Spare parts must be fitted by a competent person

**WARRANTY:** Guarantee is 12 months from purchase date, proof of which will be required for any claim.

Sealey Group, Kempson Way, Suffolk Business Park, Bury St Edmunds, Suffolk. IP32 7AR



01284 757500



sales@sealey.co.uk



www.sealey.co.uk

## TROLLEY ASSEMBLY

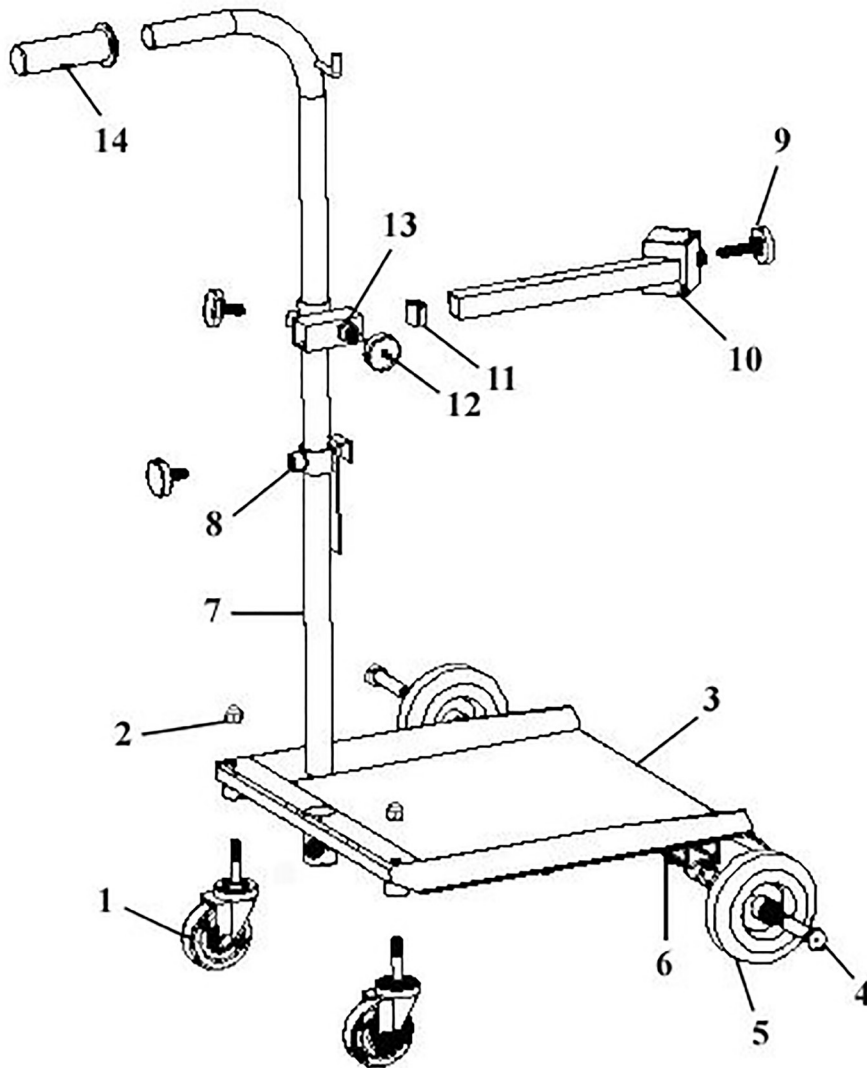

Item	Part No.	Description
1	AK453X.V3-T01	Wheel, Swivel Castor (75 x 25 x 8 x 149)
2	SN10.SD	Steel Nut M10 Domed
3	AK453X.V3-T03	Trolley Base
4	HHB1490.S	Hex Head Bolt M14 x 90mm
5	AK453X.V3-T05	Wheel, Fixed (125 x 36 x 14)
6	SN14.S	Steel Nut M14
7	AK453X.V3-T07	Handle
8	AK453X.V3-T08	Fixing Nut
9	AK453X.V3-T09	Knob (OD: 40mm) Threaded M10 x 45mm
10	AK453X.V3-T10	Holder, Grease Gun
11	AK453X.V3-T11	End Plug

Item	Part No.	Description
12	AK453X.V3-T12	Knob (OD: 39mm) Threaded M10 x 24mm
13	AK453X.V3-T13	Pump Support
14	AK453X.V3-T14	Handle Grip
--	<b>AK453X.V3-01</b>	<b>Grease Pump ***See Diagram***</b>
--	AK453X.V3-03	Drum Cover 385mm (Not Shown)
--	AK453X.V3-04	Follower Plate 370mm (Not Shown)
--	AK453X.V3-05	High Pressure Grease Hose 4m (Not Shown)
--	AK453X.V3-06	Grease Control Gun (Not Shown)
--	AK453X.V3-07	Filter/Regulator/Lubricator Assembly (Not Shown)
--	AK453X.V3-08	Z-Swivel Connector (Not Shown)
--	AK453X.V3-T	Trolley Assembly (Not Shown)

**NOTE:** It is our policy to continually improve products and as such we reserve the right to alter data, specifications and component parts without prior notice. There may be alternative versions of this product, please contact us should you require this information.

**IMPORTANT:** No liability is accepted for incorrect use of product. Spare parts must be fitted by a competent person

**WARRANTY:** Guarantee is 12 months from purchase date, proof of which will be required for any claim.