

Parts Information:
**Space Warmer® Paraffin/Kerosene/Diesel
 Heater 45,000Btu/hr without Wheels
 Model No: AB458**

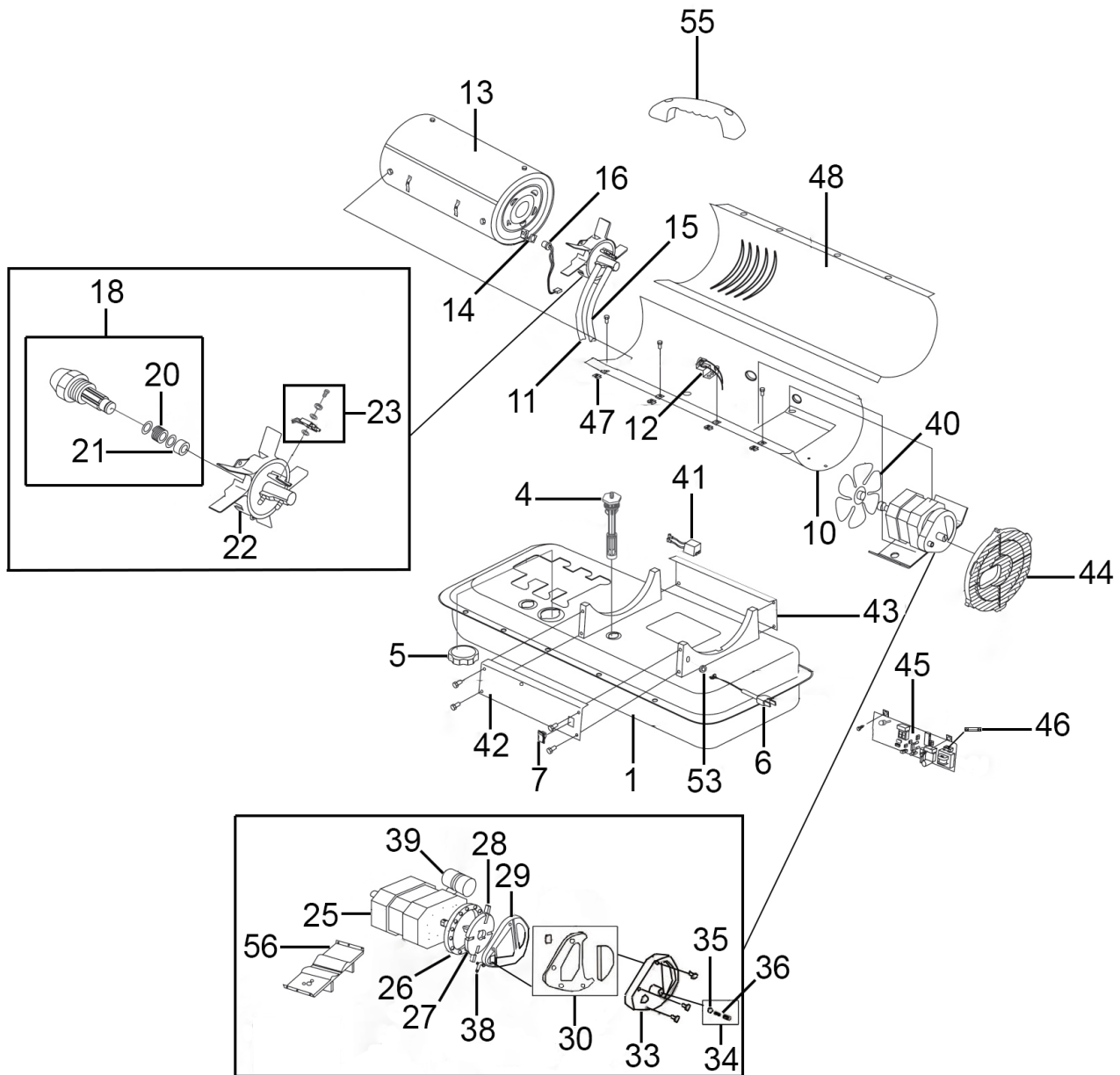

Item	Part No.	Description
1	P70-002-0100	Fuel Tank Assembly
4	P70-003-0100	Fuel Filter Assembly
5	P70-006-0120	Fuel Cap Assembly
6	MC3CX0.75	Mains Cable
7	P75-012-0110	Switch, On/Off Rocker 3A/250V
10	P70-001-0902	Lower Cover
11	P70-035-0100	Air Hose

Item	Part No.	Description
12	P70-019-0100	Thermal Cut Out Switch (B080)
13	P70-010-0100	Combustion Chamber
14	P70-010-0101	Flame Sensor Bracket
15	P70-036-0100	Fuel Hose
16	P70-016-0100	Flame Sensor
18	P70-015-0100	Nozzle - Delavan 45 K
20	P70-015-0102	Nozzle Seal Spring

NOTE: It is our policy to continually improve products and as such we reserve the right to alter data, specifications and component parts without prior notice. There may be alternative versions of this product, please contact us should you require this information.

IMPORTANT: No liability is accepted for incorrect use of product. Spare parts must be fitted by a competent person

WARRANTY: Guarantee is 12 months from purchase date, proof of which will be required for any claim.



Parts Information:
**Space Warmer® Paraffin/Kerosene/Diesel
Heater 45,000Btu/hr without Wheels
Model No: AB458**

Item	Part No.	Description
21	P70-015-0103	Nozzle Sleeve
22	P70-014-0101	Burner Head
23	P70-052-0100	Spark Plug
25	P70-021-0501	Motor (Internal 230V 50Hz)
26	P70-020-0101	Pump Body 1/2"
27	P70-022-0100	Rotor Kit 1/2" (c/w Vanes/Clip)
28	P70-022-0230	Rotor blade 1/2" (Set of 4)
29	P70-020-0102	End Pump Cover
30	P70-054-0100	Filter Kit
33	P70-020-0103	End Filter Cover
34	P70-055-0100	Plug/Pump Adjust Kit
35	SB-6.4	Steel Ball 6.4mm
36	P70-020-0105	Spring
38	P70-014-0104	Nipple
39	P70-020-0127	Capacitor 230V/50Hz 50x30
40	P70-024-0100	Fan
41	P70-037-0100	Ignitor

Item	Part No.	Description
42	P70-008-0100	Right Side Cover
43	P70-009-0100	Left Side Cover
44	P70-016-0700	Fan Guard
45	P70-027-0100	Main PCB Assembly
46	P70-027-0101	Fuse, Glass 5Amp 250V 5x20
47	P70-001-0105	Clip Nut
48	P70-001-0901	Upper Cover
53	P70-033-0100	Cord Bushing
55	P70-001-0103	Handle
56	P70-020-0610	Support Plate
--	P70-007-0100	Fuel Gauge Assembly (Not Shown)
--	P70-020-0401	Pump Body 5/8" (Not Shown)
--	P70-022-0202	Rotor Blade (Set of 4) 5/8" (Not Shown)
--	P70-025-0100	Air Pressure Gauge (Not Shown)
--	P70-056-0100	Fixing Kit (Not Shown)
--	P70-032-0100	Cord Wrap (Not Shown)
--	P70-001-0104	Hinge Pin (Not Shown)

NOTE: It is our policy to continually improve products and as such we reserve the right to alter data, specifications and component parts without prior notice. There may be alternative versions of this product, please contact us should you require this information.

IMPORTANT: No liability is accepted for incorrect use of product. Spare parts must be fitted by a competent person

WARRANTY: Guarantee is 12 months from purchase date, proof of which will be required for any claim.

Sealey Group, Kempson Way, Suffolk Business Park, Bury St Edmunds, Suffolk. IP32 7AR



01284 757500



01284 703534



sales@sealey.co.uk



www.sealey.co.uk