

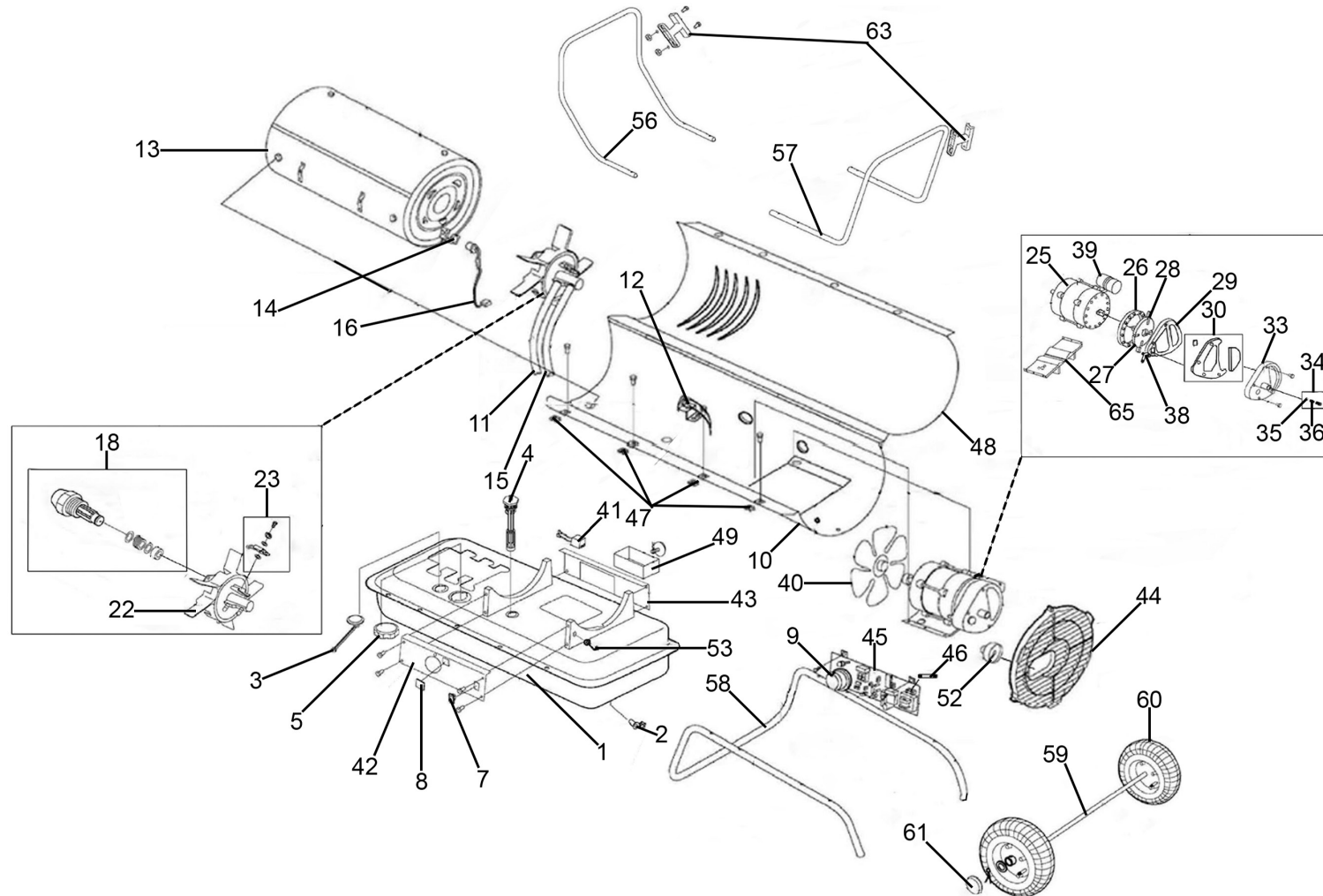

Parts Information:  
**Space Warmer® Paraffin/Kerosene/Diesel Heater 175,000Btu/hr with  
Wheels Stainless Steel  
Model No: AB1758SS**



**NOTE:** It is our policy to continually improve products and as such we reserve the right to alter data, specifications and component parts without prior notice.

There may be alternative versions of this product, please contact us should you require this information.

**IMPORTANT:** No liability is accepted for incorrect use of product. Spare parts must be fitted by a competent person

**WARRANTY:** Guarantee is 12 months from purchase date, proof of which will be required for any claim.

Sealey Group, Kempson Way, Suffolk Business Park, Bury St Edmunds, Suffolk. IP32 7AR



01284 757500



sales@sealey.co.uk



www.sealey.co.uk



Parts Information:  
**Space Warmer® Paraffin/Kerosene/  
 Diesel Heater 175,000Btu/hr with Wheels  
 Stainless Steel  
 Model No: AB1758SS**

Item	Part No.	Description	Qty
1	P70-002-0300	Fuel Tank Assembly	1
2	P70-002-0105	Drain Plug	1
3	P70-007-0200	Fuel Gauge Assembly	1
4	P70-003-0200	Fuel Filter Assembly	1
5	P70-006-0120	Fuel Cap Assembly Ø 33mm (c/w Cap & Gasket)	1
7	P75-012-0110	Switch, On/Off Rocker 3A 250V	1
8	P70-040-0100	Window Display	1
9	P70-031-0100	Knob, Thermostat Control Ø 55mm	1
10	P70-001-1660	Lower Cover	1
11	P70-035-0400	Air Hose 6 x 10 x 490mm	1
12	P70-019-0100	Thermal Cut Out Switch	1
13	P70-011-0400	Chamber Assembly	1
14	P70-010-0101	Flame Sensor Bracket	1
15	P70-036-0400	Fuel Hose 6 x 10 x 190mm	1
16	P70-016-0100	Flame Sensor (2 Pin Plug)	1
18	P70-015-0400	Nozzle - Delavan 175K	1
18	P70-015-0100	Nozzle - Delavan 45K (Alternative)	--
22	P70-014-0301	Burner Head	1
23	P70-052-0200	Spark Plug Kit	1
25	P70-021-0400	Motor 220-230V 50Hz	1
26	P70-020-0401	Pump Body 5/8"	1
27	P70-022-0200	Rotor Kit 5/8" (c/w Vanes & Clip)	1
28	P70-022-0202	Rotor Blade 5/8" (Set of 4)	1
29	P70-020-0102	End Pump Cover	1
30	P70-054-0100	Filter Kit	1
33	P70-020-0103	End Filter Cover	1
34	P70-055-0100	Plug/Pump Adjust Kit	1
35	SB-6.4	Steel ball 6.4mm	1
36	P70-020-0105	Spring	1
38	P70-014-0104	Nipple	1

Item	Part No.	Description	Qty
39	P70-020-0221	Capacitor 7µF 50/60Hz 70 x 40mm	1
40	P70-024-0400	Fan Assembly	1
41	P70-037-0120	Ignitor EU	1
42	P70-008-0400	Side Cover, Right	1
43	P70-009-0300	Side Cover, Left	1
44	P70-016-0200	Fan Guard	1
45	P70-027-0370	PCB 195 x 70mm (c/w Display & Potentiometer)	1
46	P70-027-0101	Fuse 5A 250V 5 x 20mm	1
47	P70-001-0105	Clip Nut	4
48	P70-001-1655	Upper Cover	1
49	P70-053-0100	Storage Box	1
52	P70-025-0100	Air Pressure Gauge	1
53	P70-033-0200	Cord Bushing	1
56	P70-042-0200	Front Handle	1
57	P70-043-0200	Back Handle	1
58	P70-041-0201	Wheel Support Frame	1
59	P70-041-0103	Wheel Axle 540mm Ø 12mm	1
59	P70-041-1510	Wheel Axle 560mm Ø 12mm (Alternative)	--
60	P70-041-1400	Wheel, Fixed 250 x 56 x 12mm	2
60	P70-041-0150	Wheel (Alternative)	--
61	P70-041-0104	Wheel Cap	2
63	P70-032-0200	Cord Wrap	2
65	P70-020-0404	Support Plate	1
--	P71-022-1200	Rotor Clip (Not Shown)	--
--	P70-001-0304	Hinge Pin (Not Shown)	--
--	P70-056-0200	Fixing Kit (Not Shown)	--
--	P70-028-0100L	PCB Support, Left (Not Shown)	--
--	P70-028-0100R	PCB Support, Right (Not Shown)	--

**NOTE:** It is our policy to continually improve products and as such we reserve the right to alter data, specifications and component parts without prior notice. There may be alternative versions of this product, please contact us should you require this information.

**IMPORTANT:** No liability is accepted for incorrect use of product. Spare parts must be fitted by a competent person

**WARRANTY:** Guarantee is 12 months from purchase date, proof of which will be required for any claim.

Sealey Group, Kempson Way, Suffolk Business Park, Bury St Edmunds, Suffolk. IP32 7AR



01284 757500



sales@sealey.co.uk



www.sealey.co.uk