

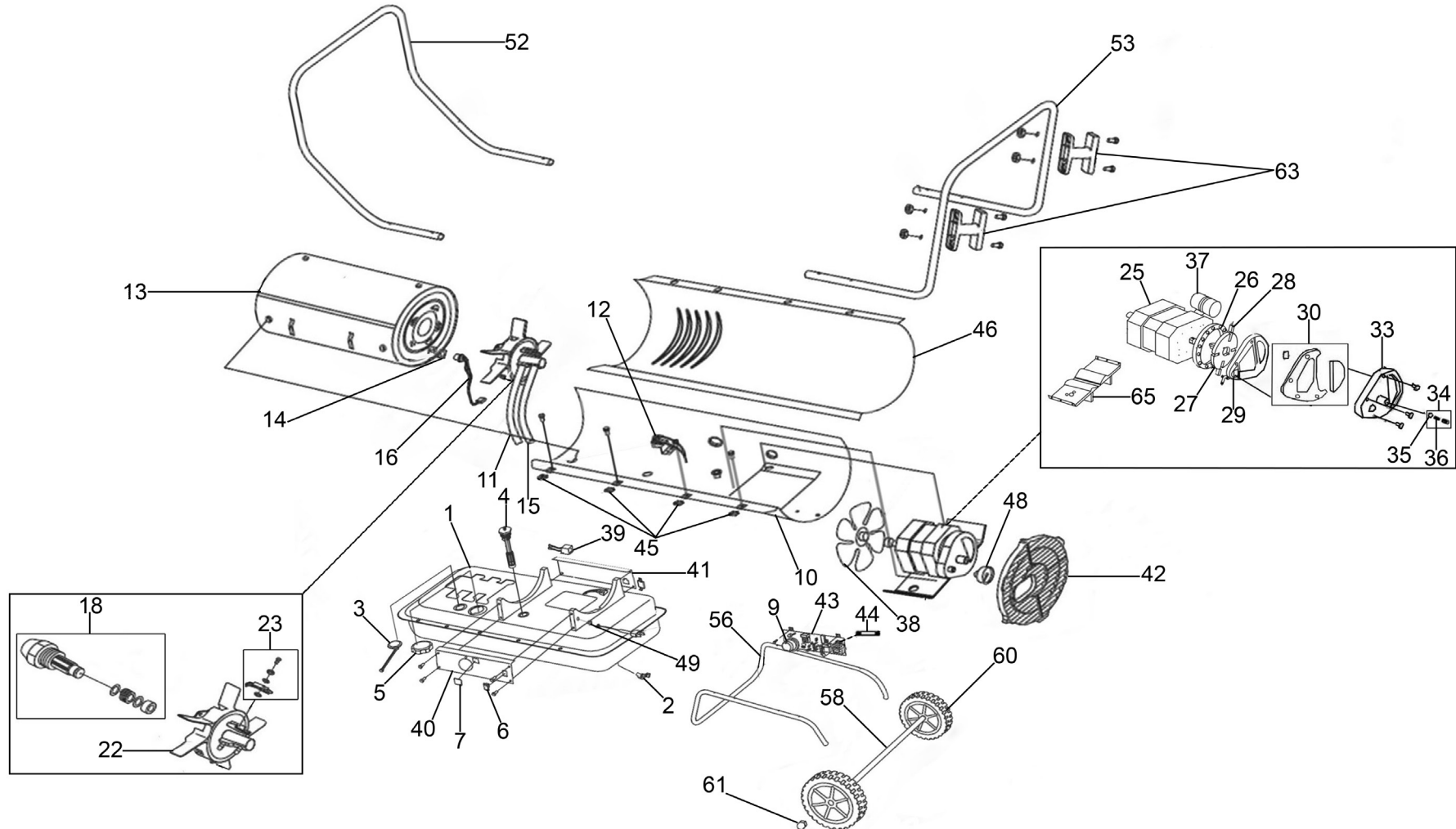

Parts Information:
**Space Warmer® Paraffin/Kerosene/Diesel Heater 125,000Btu/hr with
Wheels**
Model No: AB1258.V3



NOTE: It is our policy to continually improve products and as such we reserve the right to alter data, specifications and component parts without prior notice.

There may be alternative versions of this product, please contact us should you require this information.

IMPORTANT: No liability is accepted for incorrect use of product. Spare parts must be fitted by a competent person

WARRANTY: Guarantee is 12 months from purchase date, proof of which will be required for any claim.

Sealey Group, Kempson Way, Suffolk Business Park, Bury St Edmunds, Suffolk. IP32 7AR



01284 757500



sales@sealey.co.uk



www.sealey.co.uk



Parts Information:
**Space Warmer® Paraffin/Kerosene/Diesel
Heater 125,000Btu/hr with Wheels
Model No: AB1258.V3**

Item	Part No.	Description	Qty
1	P70-002-0200	Fuel Tank Assembly	1
2	P70-002-0105	Drain Plug	1
3	P70-007-0210	Fuel Gauge Assembly	1
4	P70-003-0200	Fuel Filter Assembly	1
5	P70-006-0120	Fuel Cap Assembly Ø 33mm (c/w Gasket)	1
6	P70-038-0110	Switch, Power Rocker 12A 250V	1
7	P70-040-0100	Window Display	1
9	P70-031-0100	Knob, Thermostat Control Ø 55mm	1
10	P70-001-1622	Lower cover	1
11	P70-035-0300	Air Hose 6mm ID	1
12	P70-019-0205	Thermal Cut Out Switch	1
13	P70-010-0300	Combustion Chamber	1
14	P70-010-0101	Flame Sensor Bracket	1
15	P70-036-0300	Fuel Hose, Rubber 6mm ID x 12mm OD x 170mm	1
16	P70-016-0100	Flame Sensor (2 Pin Plug)	1
18	P70-015-0300	Nozzle - Delavan 125k	1
--	P70-015-0100	Nozzle - Delavan 45K (Alternative)	--
22	P70-014-0301	Burner Head	1
23	P70-052-0200	Spark plug kit / Spark plug kit	1
25	P70-021-0215	Motor 100/125KFa 230V 50Hz	1
26	P70-020-0401	Pump Body 5/8"	1
27	P70-022-0200	Rotor Kit 5/8" (c/w Vanes & Clip)	1
28	P70-022-0202	Rotor Blade 5/8" (Set of 4)	1
29	P70-020-0102	End Pump Cover	1
30	P70-054-0100	Filter Kit	1

Item	Part No.	Description	Qty
33	P70-020-0103	End Filter Cover	1
34	P70-055-0100	Plug/Pump Adjust Kit	1
35	SB-6.4	Steel Ball 6.4mm	1
36	P70-020-0105	Spring	1
37	P70-020-0221	Capacitor 7µF 50/60Hz 70 x 40mm	1
38	P70-024-0300	Fan Assembly	1
39	P70-037-0120	Ignitor	1
40	P70-008-0301	Right Side Cover	1
41	P70-009-0200	Left Side Cover	1
42	P70-016-0200	Fan Guard	1
43	P70-027-0370	PCB (c/w Display & Potentiometer)	1
44	P70-027-0101	Fuse 5A 250V 5 x 20mm	1
45	P70-001-0105	Clip Nut	4
46	P70-001-1001	Upper Cover	1
48	P70-025-0100	Air Pressure Gauge	1
49	P70-033-0200	Cord Bushing	1
52	P70-042-0100	Front Handle	1
53	P70-043-0100	Back Handle	1
56	P70-041-0101	Wheel Support Frame	1
58	P70-041-1510	Wheel Axle 560mm Ø 12mm	1
60	P70-041-1400	Wheel, Fixed 250 x 56 x 12mm	2
61	SN12.SD	Steel Nut M12 Domed	2
63	P70-032-0200	Cord Wrap	2
65	P70-020-0250	Support Plate	1
--	P70-053-0100	Storage Box (Not Shown)	--
--	P70-056-0210	Fixing Kit (Not Shown)	--

NOTE: It is our policy to continually improve products and as such we reserve the right to alter data, specifications and component parts without prior notice. There may be alternative versions of this product, please contact us should you require this information.

IMPORTANT: No liability is accepted for incorrect use of product. Spare parts must be fitted by a competent person

WARRANTY: Guarantee is 12 months from purchase date, proof of which will be required for any claim.

Sealey Group, Kempson Way, Suffolk Business Park, Bury St Edmunds, Suffolk. IP32 7AR



01284 757500



sales@sealey.co.uk



www.sealey.co.uk