

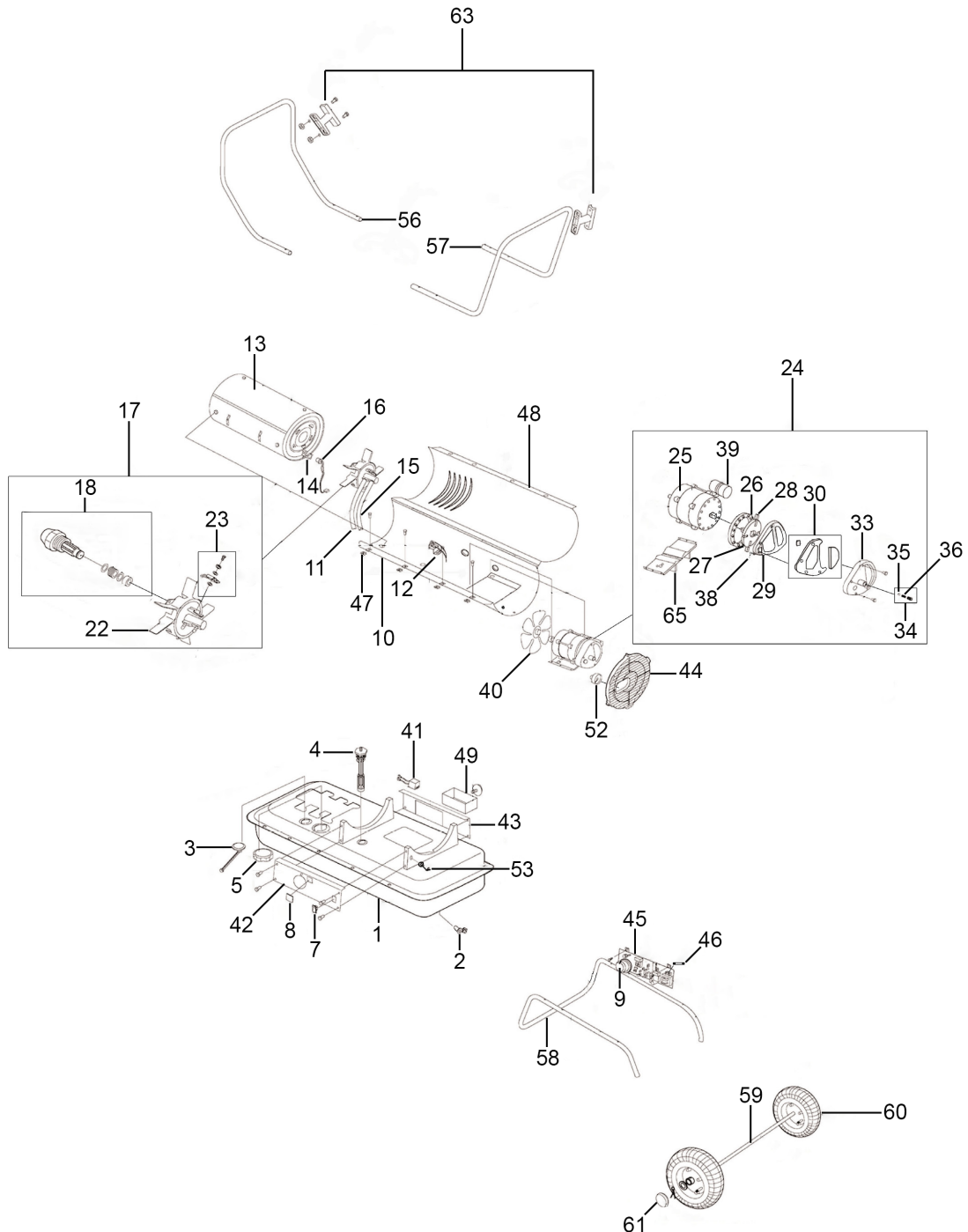

Parts Information:
Space Warmer® Paraffin/Kerosene/Diesel
Heater 125,000Btu/hr with Wheels
Model No: AB1258



NOTE: It is our policy to continually improve products and as such we reserve the right to alter data, specifications and component parts without prior notice. There may be alternative versions of this product, please contact us should you require this information.

IMPORTANT: No liability is accepted for incorrect use of product. Spare parts must be fitted by a competent person

WARRANTY: Guarantee is 12 months from purchase date, proof of which will be required for any claim.

Sealey Group, Kempson Way, Suffolk Business Park, Bury St Edmunds, Suffolk. IP32 7AR



01284 757500



01284 703534



sales@sealey.co.uk



www.sealey.co.uk



Parts Information:
**Space Warmer® Paraffin/Kerosene/Diesel
 Heater 125,000Btu/hr with Wheels
 Model No: AB1258**

Item	Part No.	Description
1	P70-002-0200	Fuel Tank Assembly
2	P70-002-0105	Drain Plug
3	P70-007-0200	Fuel Gauge Assembly
4	P70-003-0200	Fuel Filter Assembly
5	P70-006-0120	Fuel Cap Assembly
7	P75-012-0110	Switch, On/Off Rocker 3A/250V
8	P70-040-0100	Window Display
9	P70-031-0100	Thermostat Control Knob
10	P70-001-1002	Lower Cover
11	P70-035-0300	Air Hose
12	P70-019-0100	Thermal Cut Out Switch (B080)
13	P70-010-0300	Combustion Chamber
14	P70-010-0101	Flame Sensor Bracket
15	P70-036-0300	Fuel Hose
16	P70-016-0100	Flame Sensor
17	P70-014-0300	Burner Head Assembly
18	P70-015-0300	Nozzle 125k
22	P70-014-0301	Burner Head
23	P70-052-0200	Spark Plug Kit
24	P70-020-0300	Motor and Pump Assembly
25	P70-021-0220	Motor 230V/50Hz
26	P70-020-0101	Pump Body 1/2"
27	P70-022-0100	Rotor Kit 1/2" (c/w Vanes/Clip)
28	P70-022-0230	Rotor Blade 1/2" (Set of 4)
29	P70-020-0102	End Pump Cover
30	P70-054-0100	Filter Kit
33	P70-020-0103	End Filter Cover
34	P70-055-0100	Plug/Pump Adjust Kit
35	SB-6.4	Steel Ball 6.4mm
36	P70-020-0105	Spring
38	P70-014-0104	Nipple
39	P70-020-0221	Capacitor C65R 12uF 50/60Hz 70x40
40	P70-024-0300	Fan Assembly

Item	Part No.	Description
41	P70-037-0300	Ignitor
42	P70-008-0301	Right Side Cover
43	P70-009-0200	Left Side Cover
44	P70-016-0200	Fan Guard
45	P70-027-0370	Main PCB Assembly
46	P70-027-0101	Fuse, Glass 5Amp 250V 5x20
47	P70-001-0105	Clip Nut
48	P70-001-1001	Upper Cover
49	P70-053-0100	Storage Box
52	P70-025-0100	Air Pressure Gauge
53	P70-033-0200	Cord Bushing
56	P70-042-0100	Front Handle
57	P70-043-0100	Back Handle
58	P70-041-0101	Wheel Support Frame
59	P70-041-0103	Wheel Axle
60	P70-041-0150	Wheel, Pneumatic
61	P70-041-0104	Wheel Cap
63	P70-032-0200	Cord Wrap
65	P70-020-0250	Support Plate
--	MC3CX1.5	Mains Cable (Not Shown)
--	P70-020-0401	Pump Body 5/8" (Not Shown)
--	P70-022-0210	Rotor Kit 5/8" (Not Shown)
--	P71-022-1200	Rotor Clip (Not Shown)
--	P70-022-0202	Rotor Blade (Set of 4) 5/8" (Not Shown)
--	P70-041-1510	Wheel Axle (Not Shown)
--	P70-041-1400	Wheel, Fixed Plastic (Not Shown)
--	P70-056-0200	Fixing Kit (Not Shown)
--	P70-001-0204	Hinge Pin (Not Shown)
--	P70-028-0100	Pcb Support (Not Shown)
--	P70-016-0115	Room Sensor Cable (Not Shown)
--	P70-021-0511	Motor, Internal 230V 50Hz (Not Shown)
--	P70-016-0115	Room Sensor Cable (Not Shown)
--	P70-021-0511	Motor, Internal 230V 50Hz (Not Shown)

NOTE: It is our policy to continually improve products and as such we reserve the right to alter data, specifications and component parts without prior notice. There may be alternative versions of this product, please contact us should you require this information.

IMPORTANT: No liability is accepted for incorrect use of product. Spare parts must be fitted by a competent person

WARRANTY: Guarantee is 12 months from purchase date, proof of which will be required for any claim.

Sealey Group, Kempson Way, Suffolk Business Park, Bury St Edmunds, Suffolk. IP32 7AR



01284 757500



01284 703534



sales@sealey.co.uk



www.sealey.co.uk