

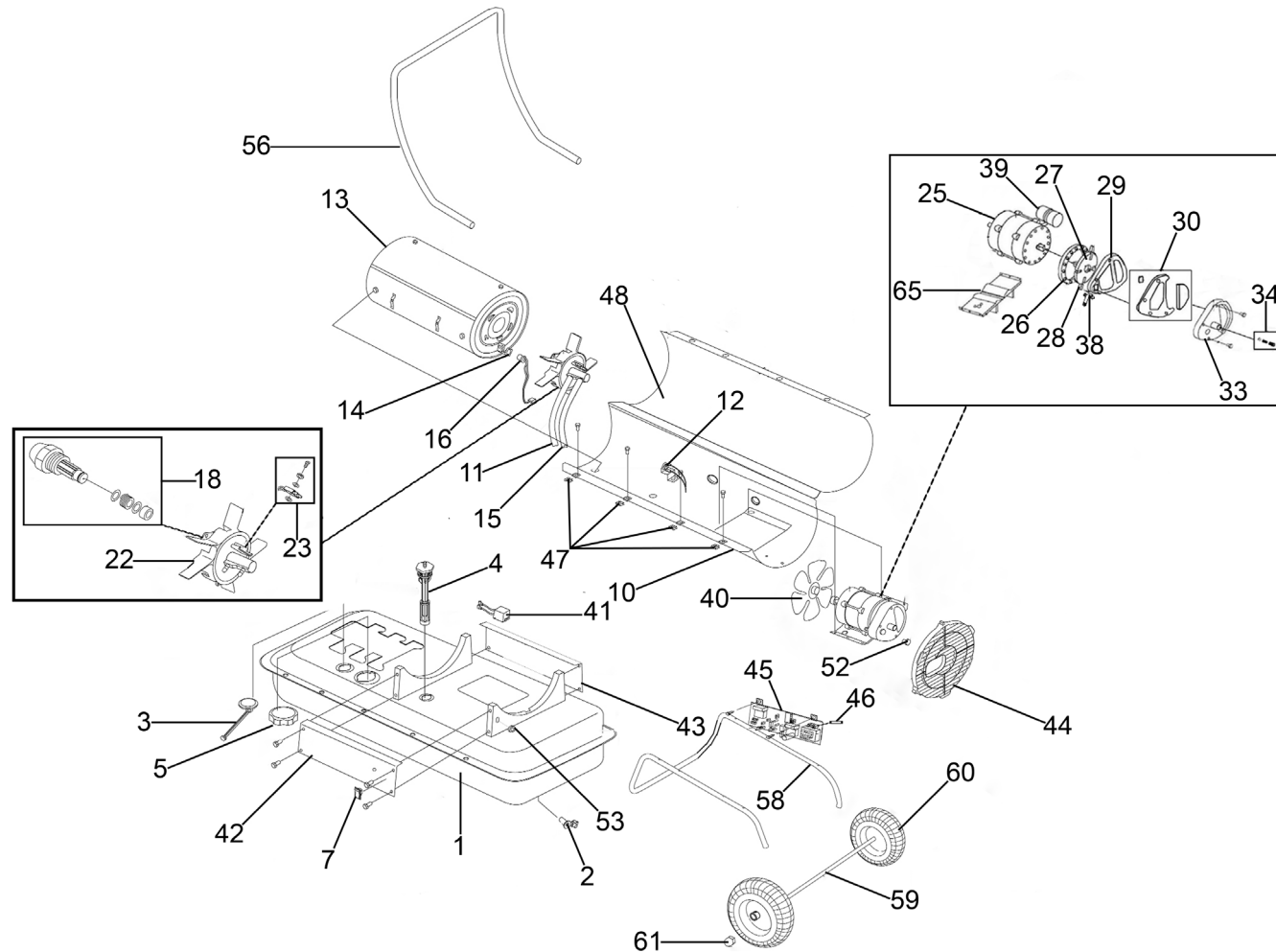

Parts Information:
**Space Warmer® Paraffin/Kerosene/Diesel Heater 100,000Btu/hr with
Wheels**
Model No: AB100E



NOTE: It is our policy to continually improve products and as such we reserve the right to alter data, specifications and component parts without prior notice.

There may be alternative versions of this product, please contact us should you require this information.

IMPORTANT: No liability is accepted for incorrect use of product. Spare parts must be fitted by a competent person

WARRANTY: Guarantee is 12 months from purchase date, proof of which will be required for any claim.

Sealey Group, Kempson Way, Suffolk Business Park, Bury St Edmunds, Suffolk. IP32 7AR



01284 757500



sales@sealey.co.uk



www.sealey.co.uk



Parts Information:
Space Warmer® Paraffin/Kerosene/Diesel
Heater 100,000Btu/hr with Wheels
Model No: AB100E

Item	Part No.	Description	Qty
1	P70-002-0200	Fuel Tank Assembly	1
2	P70-002-0105	Drain Plug	1
3	P70-007-0210	Fuel Gauge Assembly	1
4	P70-003-0200	Fuel Filter Assembly	1
5	P70-006-0120	Fuel cap Assembly Ø 33mm (c/w Gasket)	1
7	P70-038-0110	Switch, Power Rocker 12A 250V	1
10	P70-001-1622	Lower Cover	1
11	P70-035-0300	Air Hose (6mm ID)	1
12	P70-019-0205	Thermal Cut Out Switch	1
13	P70-011-0300	Combustion Chamber	1
14	P70-010-0101	Flame Sensor Bracket	1
15	P70-036-0300	Fuel Hose, Rubber (6mm ID x 12mm OD x 170mm)	1
16	P70-016-0100	Flame Sensor (2 Pin Plug)	1
18	P70-015-0100	Nozzle - Delavan 45K	1
22	P70-014-0301	Burner Head	1
23	P70-052-0210	Spark Plug	1
25	P70-021-0511	Motor 230V 50Hz	1
26	P70-020-0401	Pump Body 5/8"	1
27	P70-022-0200	Rotor Kit 5/8" (c/w Vanes & Clip)	1
28	P70-022-0202	Rotor Blade 5/8" (Set of 4)	1
29	P70-020-0102	End Pump Cover	1
30	P70-054-0100	Filter Kit	1
33	P70-020-0103	End Filter Cover	1
34	P70-055-0100	Plug/Pump Adjust Kit	1

Item	Part No.	Description	Qty
38	P70-014-0104	Nipple	1
39	P70-020-0220	Capacitor	1
40	P70-024-0300	Fan Assembly	1
41	P70-037-0120	Ignitor	1
42	P70-008-0300	Right Side Cover	1
43	P70-009-0150	Left Side Cover	1
44	P70-016-0200	Fan Guard	1
45	P70-027-0160	PCB 140 X 60mm (c/w LED & Fuse)	1
46	P70-027-0101	Fuse Glass 5A 250V 5 x 20mm	1
47	P70-001-0105	Clip Nut	4
48	P70-001-1001	Upper Cover	1
52	P70-002-0110	End Cover Plug	1
53	P70-033-0200	Cord Bushing	1
56	P70-042-0100	Front Handle	1
58	P70-041-0101	Wheel Support Frame	1
59	P70-041-0103	Wheel Axle 540mm Ø 12mm	1
--	P70-041-1510	Wheel Axle 560mm Ø 12mm (Alternative)	--
60	P70-041-0150	Wheel	2
--	P70-041-1400	Wheel, Fixed 250 x 56 x 12mm	--
61	SN12.SD	Steel Nut M12 Domed	2
65	P70-020-0610	Support Plate	1
--	P70-040-0100	Window Display (Not Shown)	--
--	SB-6.4	Steel Ball 6.4mm (Not Shown)	--
--	P70-020-0105	Spring (Not Shown)	--

NOTE: It is our policy to continually improve products and as such we reserve the right to alter data, specifications and component parts without prior notice. There may be alternative versions of this product, please contact us should you require this information.

IMPORTANT: No liability is accepted for incorrect use of product. Spare parts must be fitted by a competent person

WARRANTY: Guarantee is 12 months from purchase date, proof of which will be required for any claim.

Sealey Group, Kempson Way, Suffolk Business Park, Bury St Edmunds, Suffolk. IP32 7AR



01284 757500



sales@sealey.co.uk



www.sealey.co.uk