

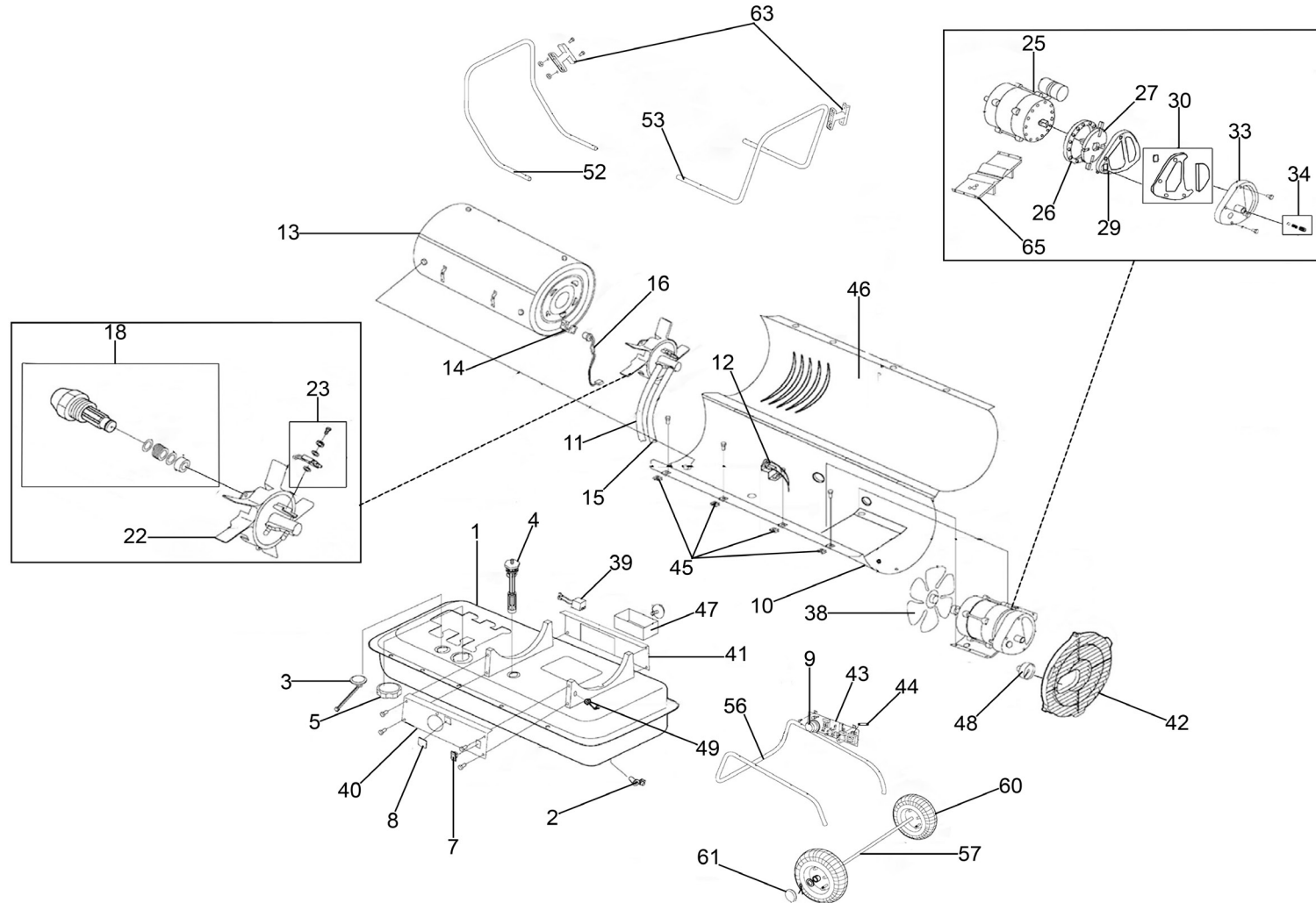

Parts Information:  
**Space Warmer® Paraffin/Kerosene/Diesel Heater 100,000Btu/hr with  
Wheels**  
**Model No: AB1008.V2**



**NOTE:** It is our policy to continually improve products and as such we reserve the right to alter data, specifications and component parts without prior notice.

There may be alternative versions of this product, please contact us should you require this information.

**IMPORTANT:** No liability is accepted for incorrect use of product. Spare parts must be fitted by a competent person

**WARRANTY:** Guarantee is 12 months from purchase date, proof of which will be required for any claim.

Sealey Group, Kempson Way, Suffolk Business Park, Bury St Edmunds, Suffolk. IP32 7AR



01284 757500



sales@sealey.co.uk



www.sealey.co.uk



Parts Information:  
**Space Warmer® Paraffin/Kerosene/Diesel  
 Heater 100,000Btu/hr with Wheels  
 Model No: AB1008.V2**

Item	Part No.	Description	Qty
1	P70-002-0200	Fuel Tank Assembly	1
2	P70-002-0105	Drain Plug	1
3	P70-007-0210	Fuel Gauge Assembly	1
4	P70-003-0200	Fuel Filter Assembly	1
5	P70-006-0120	Fuel Cap Assembly Ø 33mm	1
7	P70-038-0110	Switch, Power Rocker 12A 250v	1
8	P70-040-0100	Window Display	1
9	P70-031-0100	Knob, Thermostat Control Ø 55mm	1
10	P70-001-1622	Lower Cover	1
11	P70-035-0300	Air Hose Ø 6mm	1
12	P70-019-0205	Thermal Cut Out Switch	1
13	P70-011-0300	Combustion Chamber	1
14	P70-010-0101	Flame Sensor Bracket	1
15	P70-036-0300	Fuel Hose, Rubber (6mm ID x 12mm OD x 170mm)	1
16	P70-016-0100	Flame Sensor (2 Pin Plug)	1
18	P70-015-0100	Nozzle - Delavan 45K	1
22	P70-014-0301	Burner Head	1
23	P70-052-0210	Spark Plug	1
25	P70-021-0215	Motor 100/125KFa 230v 50hz	1
26	P70-020-0401	Pump Body 5/8"	1
27	P70-022-0200	Rotor Kit 5/8" (c/w Vanes & Clip)	1
29	P70-020-0102	End Pump Cover	1
30	P70-054-0100	Filter Kit	1
33	P70-020-0103	End Filter Cover	1
34	P70-055-0100	Plug/Pump Adjust Kit	1
38	P70-024-0300	Fan Assembly	1
39	P70-037-0120	Ignitor	1

Item	Part No.	Description	Qty
40	P70-008-0300	Right Side Cover	1
41	P70-009-0200	Left Side Cover	1
42	P70-016-0200	Fan Guard	1
43	P70-027-0370	PCB 195 x 70mm (c/w Display & Potentiometer)	1
44	P70-027-0101	Fuse 5A 250v 5 x 20mm	1
45	P70-001-0105	Clip Nut	4
46	P70-001-1001	Upper Cover	1
47	P70-053-0100	Storage Box	1
48	P70-025-0100	Air Pressure Gauge	1
49	P70-033-0200	Cord Bushing	1
52	P70-042-0100	Front Handle	1
53	P70-043-0100	Back Handle	1
56	P70-041-0101	Wheel Support Frame	1
57	P70-041-0103	Wheel Axle 540mm Ø 12mm	1
60	P70-041-1400	Wheel 250 x 56 x 12mm	2
61	P70-041-0104	Wheel Cap	2
63	P70-032-0200	Cord Wrap	2
65	P70-020-0250	Support Plate	1
--	P70-015-0300	Nozzle - Delavan 125K (Not Shown)	--
--	P70-022-0202	Rotor Blade 5/8" (Set Of 4) (Not Shown)	--
--	SB-6.4	Steel Ball 6.4mm (Not Shown)	--
--	P70-020-0105	Spring (Not Shown)	--
--	P70-041-1510	Wheel Axle 560mm Ø 12mm (Not Shown)	--
--	P70-056-0210	Fixing Kit (Not Shown)	--

**NOTE:** It is our policy to continually improve products and as such we reserve the right to alter data, specifications and component parts without prior notice. There may be alternative versions of this product, please contact us should you require this information.

**IMPORTANT:** No liability is accepted for incorrect use of product. Spare parts must be fitted by a competent person

**WARRANTY:** Guarantee is 12 months from purchase date, proof of which will be required for any claim.

Sealey Group, Kempson Way, Suffolk Business Park, Bury St Edmunds, Suffolk. IP32 7AR



01284 757500



sales@sealey.co.uk



www.sealey.co.uk