

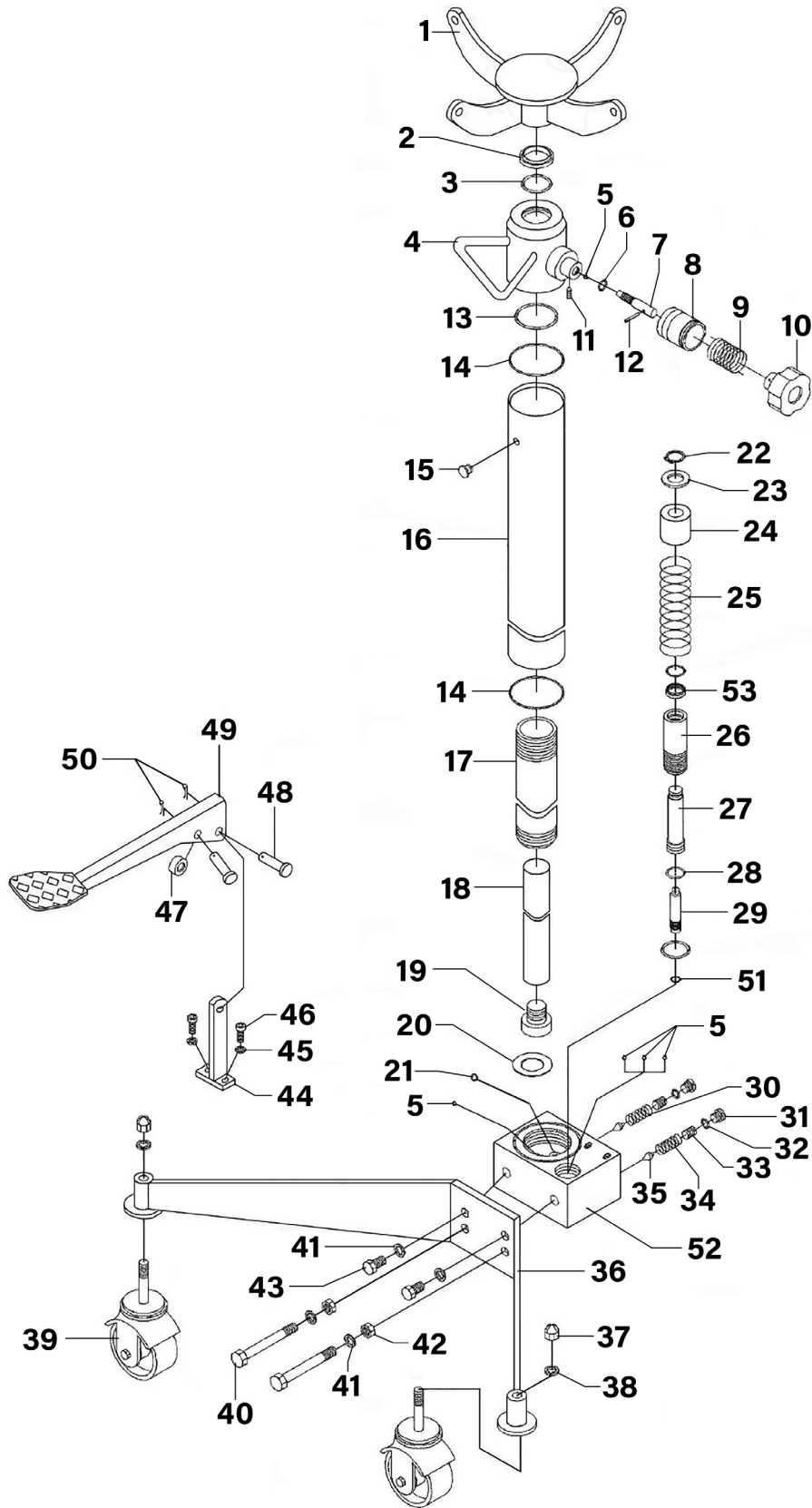

Parts Information:
Transmission Jack 600kg Vertical Quick
Lift
Model No: 600TRQ.V2



NOTE: It is our policy to continually improve products and as such we reserve the right to alter data, specifications and component parts without prior notice. There may be alternative versions of this product, please contact us should you require this information.

IMPORTANT: No liability is accepted for incorrect use of product. Spare parts must be fitted by a competent person

WARRANTY: Guarantee is 12 months from purchase date, proof of which will be required for any claim.

Sealey Group, Kempson Way, Suffolk Business Park, Bury St Edmunds, Suffolk. IP32 7AR



01284 757500



sales@sealey.co.uk



www.sealey.co.uk



Parts Information:
**Transmission Jack 600kg Vertical Quick
Lift**
Model No: 600TRQ.V2

Item	Part No.	Description
1	600TRQ.V2-01	Saddle (30mm Hole)
2	600TRQ.V2-02	Seal Ring
3	600TRQ.V2-03	O-Ring, (Ex: 35.51 In: 29.51 Cs: 3)
4	600TRQ.V2-04	Cylinder Head Ass'y
5	SB-6.0	Steel Ball 6.0mm
6	300TRQ.V2-06	O-Ring, (Ex: 15.35 In: 10.59 Cs: 2.38)
7	300TRQ.V2-07	Release Rod
8	300TRQ.V2-08	Bush
9	300TRQ.V2-09	Spring Dia 26.5mm
10	300TRQ.V2-10	Knob, Release, Plastic, OD: 60mm, M10 Threaded Female Fittin
11	GSM58.S	Grub Screw M5x8 (Single)
12	300TRQ.V2-12	Spring Pin M4 X 24
13	600TRQ.V2-13	O-Ring, (Ex: 45.39 In: 39.15 Cs: 3.12)
14	600TRQ.V2-14	O-Ring, (Ex: 70.67 In: 64.67 Cs: 3)
15	1000TRQ.V2-15	Oil Filler Plug
16	600TRQ.V2-16	Oil Reservoir
17	600TRQ.V2-17	Cylinder
18	600TRQ.V2-18	Piston Rod
19	600TRQ.V2-19	Piston Screw
20	600TRQ.V2-20	Steel Seal
21	600TRQ.V2-21	Steel Ball (Bigger)
22	SM353CEV2.048	External Circlip 18.4mm ID
23	RW1656.S	Repair Washer M16 X 56 Zinc
24	300TRQ.V2-24	Bush
25	300TRQ.V2-25	Spring Dia 60mm
26	300TRQ.V2-26	Pump Cylinder
27	300TRQ.V2-27	Outer Pump Piston

Item	Part No.	Description
28	300TRQ.V2-28	O-Ring, (Ex: 20.22 In: 15.56 Cs: 2.33)
29	300TRQ.V2-29	Inner Pump Piston
30	300TRQ.V2-30	Overload Spring Dia 7.7mm
31	300TRQ.V2-31	Screw
32	DH03.V2-39	O-Ring, (Ex: 12.81 In: 9.25 Cs: 1.78)
33	300TRQ.V2-33	Screw
34	300TRQ.V2-34	Quick Lift Spring Dia 7.6mm
35	300TRQ.V2-35	Taper Valve
36	600TRQ.V2-36	Leg
37	SN12.SD	Steel Nut M12 Domed Zinc
38	SWM12.SB	Spring Washer M12 Black
39	600TRQ.V2-39	Wheel, Swivel Castor, Single Bolt (D:78 W:31 B:10 H:172)
40	HHB10120.S	Hex Head Bolt M10 x 120mm
41	SWM10.S	Spring Washer M10 Zinc
42	SN10.S	Steel Nut M10 Zinc
43	SS1020.S	Hex Head Set Screw M10 X 20 Zinc
44	300TRQ.V2-44	Linkage Stand
45	SWM8.SB	Spring Washer M8 Black
46	SCB825.S	Socket Cap Bolt M8 x 25mm
47	300TRQ.V2-47	Pedal Bearing Bush
48	300TRQ.V2-48	Pin (10mm dia x 25mm)
49	300TRQ.V2-49	Pump Pedal
49	SF4606035100	Foot Pedal
50	300TRQ.V2-50	R-Clip 4.3 X 1.4mm
51	300TRQ.V2-51	O-Ring, (Ex: 18.32 In: 13.62 Cs: 2.35)
52	600TRQ.V2-52	Pump Base
53	300TRQ.V2-53	Seal 30*38*7

NOTE: It is our policy to continually improve products and as such we reserve the right to alter data, specifications and component parts without prior notice. There may be alternative versions of this product, please contact us should you require this information.

IMPORTANT: No liability is accepted for incorrect use of product. Spare parts must be fitted by a competent person

WARRANTY: Guarantee is 12 months from purchase date, proof of which will be required for any claim.

Sealey Group, Kempson Way, Suffolk Business Park, Bury St Edmunds, Suffolk. IP32 7AR



01284 757500



sales@sealey.co.uk



www.sealey.co.uk