

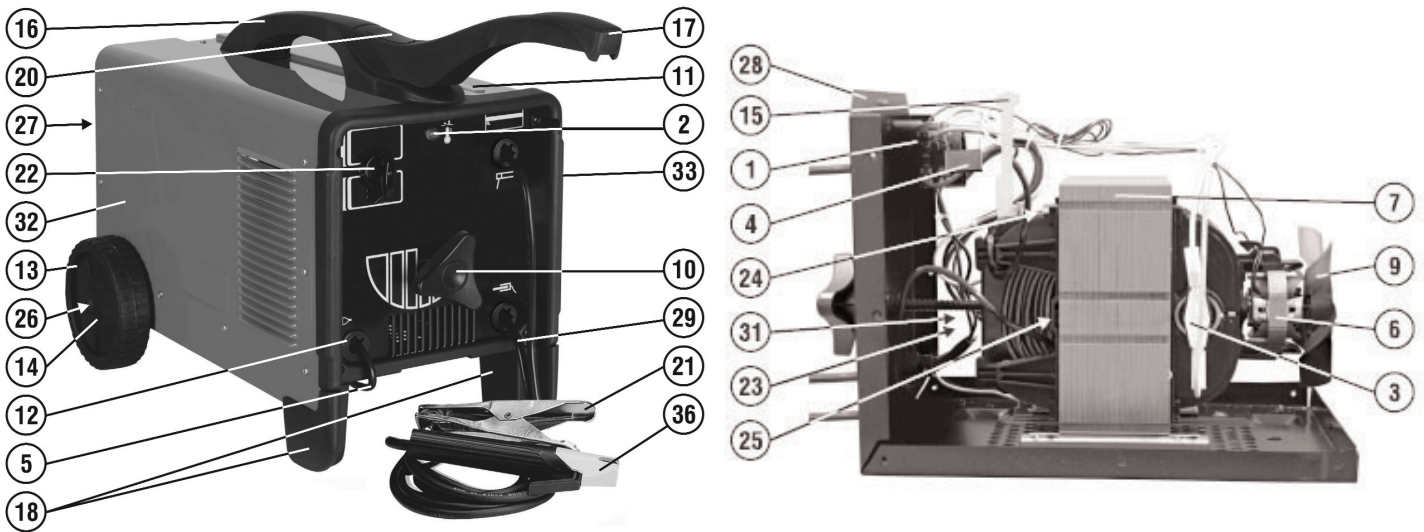

Parts Information:
Arc Welder 200Amp with Accessory Kit
Model No: 200XTC.V3

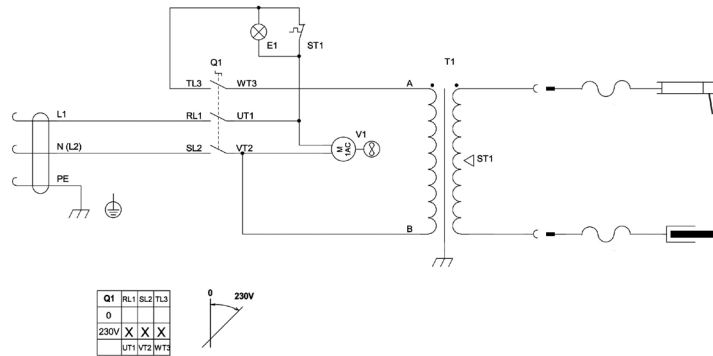

WIRING DIAGRAM



| Item | Part No. | Description |
|------|------------|---|
| 1 | 120/122506 | SWITCH (SCH 0203/5738) |
| 2 | 120/122654 | PILOT LAMP, SLIM 250V |
| 3 | 120.121259 | THERMOSTAT |
| 5 | 120/132267 | MAINS CABLE 3G02.50 2.50M |
| 6 | 120/152080 | MOTOR, ELECTROFAN |
| 7 | 120.169523 | TRANSFORMER |
| 9 | 120/312025 | BLADE, FAN |
| 10 | 120/313017 | HANDWHEEL |
| 11 | 120/322063 | TRANSPARENT PLATE |
| 12 | 120.322112 | BUSHING |
| 13 | 120/322193 | WHEEL |
| 14 | 120/322223 | CAP, AXLE |
| 15 | 120.322488 | REGULATION INDICATOR (NEW VERSION - PLAS) |
| 16 | 120.322677 | HANDLE |
| 17 | 120.322678 | HANDLE |
| 18 | 120.322750 | FEET KIT |
| -- | 120.322681 | CAP FOR HANDLE (NOT SHOWN) |

| Item | Part No. | Description |
|------|-------------|--|
| 20 | 120.322682 | HANDLE CAP |
| 21 | 120/712231 | WORK CLAMP |
| 22 | 120.323101 | SWITCH KNOB SET (WAS 322901) |
| 23 | 120/422502 | YOKE |
| 24 | 120/452085 | ANTI-VIBRATION SPRING |
| 25 | 120/452092 | SPRING |
| 26 | 120.482783 | WHEELS AXLE |
| 27 | 120/644650 | PANEL |
| 28 | 120.649705 | FRONT PANEL |
| 29 | CC16/1 | 16MM COPPER CABLE PER METER |
| 31 | 120/990417 | SHUNT KIT |
| 32 | 120.980009 | COVER KIT |
| 33 | 120.322675 | FRAME |
| 36 | 120/713063 | CLAMP AND CABLE ASSEMBLY |
| -- | MIG/7K06 | MIG WIRE MILD STEEL 0.7kg 0.6mm A18 GRAD (NOT SHOWN) |
| -- | MSP625.S | MACHINE SCREW PAN HEAD PHILLIPS M6x25mm (NOT SHOWN) |
| -- | 120/232125R | CIRCLIP (NOT SHOWN) |

NOTE: It is our policy to continually improve products and as such we reserve the right to alter data, specifications and component parts without prior notice.

IMPORTANT: No liability is accepted for incorrect use of product.

WARRANTY: Guarantee is 12 months from purchase date, proof of which will be required for any claim.

Sealey Group, Kempson Way, Suffolk Business Park, Bury St Edmunds, Suffolk. IP32 7AR



01284 757500



01284 703534



sales@sealey.co.uk



www.sealey.co.uk