

WIRING DIAGRAM

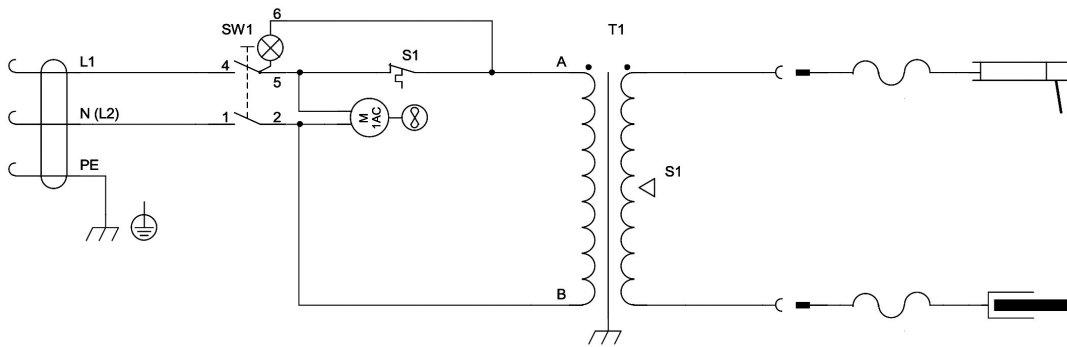

Item	Part No.	Description
2	120.121258	THERMOSTAT
5	MC3CX1.5	MAINS CABLE BLK, 3 CORE, 1.5MM2
6	120/152080	MOTOR, ELECTROFAN
7	120.169517	TRANSFORMER
8	120/312025	BLADE, FAN
10	120/313016	KNOB
11	120/322063	TRANSPARENT PLATE
12	120.322112	BUSHING
13	120/322193	WHEEL
14	120.322488	REGULATION INDICATOR (NEW VERSION - PLAS)
15	120.322675	FRAME
16	120.322677	HANDLE
17	120.322678	HANDLE
18	120.322750	FEET KIT
--	120.322681	CAP FOR HANDLE (NOT SHOWN)

Item	Part No.	Description
20	120.322682	HANDLE CAP
23	120/422502	YOKE
24	120/452085	ANTI-VIBRATION SPRING
25	120/452092	SPRING
26	120.482783	WHEELS AXLE
27	120/644420	PANEL
28	120.649704	FRONT PANEL
31	120/990416	KIT
32	120.980008	COVER KIT
33	120/322223	CAP, AXLE
34	120/122752	SWITCH, ROCKER ILLUMINATED
35	CC16/1	16MM COPPER CABLE PER METER
36	120/713063	CLAMP AND CABLE ASSEMBLY
--	MIG/7K06	MIG WIRE MILD STEEL 0.7kg 0.6mm A18 GRAD (NOT SHOWN)
37	120/712231	WORK CLAMP

NOTE: It is our policy to continually improve products and as such we reserve the right to alter data, specifications and component parts without prior notice.

IMPORTANT: No liability is accepted for incorrect use of product.

WARRANTY: Guarantee is 12 months from purchase date, proof of which will be required for any claim.